

GEOGUIDE 7

**GUIDE TO
SOIL NAIL DESIGN AND
CONSTRUCTION**

**GEOTECHNICAL ENGINEERING OFFICE
Civil Engineering and Development Department
The Government of the Hong Kong
Special Administrative Region**

GEOGUIDE 7

**GUIDE TO
SOIL NAIL DESIGN AND
CONSTRUCTION**

**GEOTECHNICAL ENGINEERING OFFICE
Civil Engineering and Development Department
The Government of the Hong Kong
Special Administrative Region**

© The Government of the Hong Kong Special Administrative Region

First published, March 2008

Prepared by:

Geotechnical Engineering Office,
Civil Engineering and Development Department,
Civil Engineering and Development Building,
101 Princess Margaret Road,
Homantin, Kowloon,
Hong Kong.

FOREWORD

This Geoguide presents a recommended standard of good practice for the design, construction, monitoring and maintenance of soil-nailed systems in Hong Kong. The Geoguide summarises the experience gained from the use of the soil nailing technique in Hong Kong and the findings of related technical development work. The recommended good practice set out in this Geoguide primarily covers the use of high yield deformed steel bars installed by the drill-and-grout method for reinforcing slopes, retaining walls and excavations.

The compilation of this Geoguide was supported by a series of soil nail related studies initiated by the Geotechnical Engineering Office (GEO), researchers and practitioners, which facilitated development of systematic guidelines on design and construction to enhance the reliability of soil-nailed systems. The studies included literature reviews, field tests, laboratory investigations and numerical modelling. Some of the findings have already been presented in technical publications and promulgated in GEO reports and technical guidance notes.

The preparation of this Geoguide was overseen by a Working Group. The membership of the Working Group, given on the next page, included representatives from relevant government works departments, the Hong Kong Institution of Engineers (Geotechnical Division) and Landslip Preventive Measures (LPM) Contractors. The Management Committee of the GEO provided overall steering to the preparation of the Geoguide.

To ensure that the Geoguide would be accepted as a consensus document by interested parties in Hong Kong, a draft version was circulated locally and abroad for comment in late 2007. Those consulted included professional bodies, consulting engineers, contractors, academics and government departments. The document was also posted on the website of the Civil Engineering and Development Department for public comment. Many individuals and organisations made useful comments, which have been taken into account in finalising this Geoguide. All contributions are gratefully acknowledged.

As with other Geoguides, this document gives guidance on good engineering practice, and its recommendations are not intended to be mandatory. As experience and good practice evolve, practitioners are encouraged to provide comments to the Geotechnical Engineering Office at any time on the contents of this Geoguide, so that improvements can be made to future editions.



R.K.S. Chan

Head, Geotechnical Engineering Office
Civil Engineering and Development Department
March 2008

WORKING GROUP :

Architectural Services Department

Mr. Joseph Wong C.P.

Civil Engineering and Development Department

Mr. Pun W.K. (Chairman)

Mr. Herman Shiu Y.K.

Mr. Charles Chan H.C.

Mr. Stephen Yip C.T.

Mr. Choi Y.C.

Mr. Lawrence Shum K.W.

Dr. Raymond Cheung W.M. (Secretary)

Highways Department

Mr. Andy Wong H.T.

Housing Department

Mr. Raymond Wong M.W.

LPM Contractors

Mr. Cheung T.K.

The Hong Kong Institution of Engineers (Geotechnical Division)

Dr. Eric Li S.F.

CONTENTS

	Page No.
TITLE PAGE	1
FOREWORD	3
CONTENTS	5
LIST OF TABLES	9
LIST OF FIGURES	10
1. INTRODUCTION	13
1.1 PURPOSE AND SCOPE	13
2. APPLICATIONS	15
2.1 GENERAL	15
2.2 DEVELOPMENT OF THE SOIL NAILING TECHNIQUE	15
2.3 AREAS OF APPLICATION	15
2.4 FUNDAMENTALS OF A SOIL-NAILED SYSTEM	16
2.4.1 Installation Methods	16
2.4.2 Basic Elements of a Soil-nailed System	17
2.5 MERITS AND LIMITATIONS	19
3. PRINCIPLES OF A SOIL-NAILED SYSTEM	21
3.1 GENERAL	21
3.2 CLASSIFICATION OF A SOIL-NAILED SYSTEM	21
3.3 FUNDAMENTAL MECHANISM OF A SOIL-NAILED SYSTEM	21

	Page No.
3.4 NAIL-GROUND INTERACTION	22
4. SITE INVESTIGATION AND TESTING	27
4.1 GENERAL	27
4.2 BUILDABILITY OF SOIL NAILS	27
4.3 DURABILITY OF SOIL NAILS	29
4.3.1 General	29
4.3.2 Soil Aggressivity	29
4.3.3 Soil Aggressivity Assessment	30
5. DESIGN OF A SOIL-NAILED SYSTEM	33
5.1 GENERAL	33
5.2 DESIGN CONSIDERATIONS	33
5.3 DESIGN FOR STABILITY	34
5.3.1 General	34
5.3.2 Modes of Failure	34
5.3.3 Models	36
5.3.4 Methods of Stability Analysis	37
5.4 DESIGN FOR SERVICEABILITY	37
5.5 DESIGN FOR DURABILITY	38
5.6 ANALYTICAL DESIGN OF SOIL NAILS IN SOIL CUT SLOPES	40
5.6.1 General	40
5.6.2 Factor of Safety	40
5.6.3 Soil-nail Reinforcement	43
5.6.4 Soil-nail Head	46
5.6.5 Slope Facing	48
5.7 ANALYTICAL DESIGN OF SOIL NAILS IN RETAINING WALLS	50
5.7.1 General	50
5.7.2 Factor of Safety	51
5.7.3 Soil-nail Reinforcement	52
5.7.4 Soil-nail Head and Facing	52
5.8 ANALYTICAL DESIGN OF SOIL NAILS IN FILL SLOPES	56
5.8.1 General	56

	Page No.	
5.8.2	Factor of Safety	56
5.8.3	Design against Liquefaction	57
5.8.4	Soil-nail Reinforcement	58
5.9	PREScriptive DESIGN OF SOIL NAILS IN EXISTING SOIL CUT SLOPES AND RETAINING WALLS	58
5.10	DRAINAGE PROVISION	59
5.11	AESTHETICS AND LANDSCAPE TREATMENT	60
5.12	DESIGN OF SOIL NAILS IN SPECIFIC CIRCUMSTANCES	61
5.12.1	General	61
5.12.2	Design of Soil Nails Carrying Sustained Loads	63
5.12.3	Design of Soil Nails in Temporary Excavations	64
5.12.4	Design of Soil Nails using Alternative Reinforcement Materials	64
6.	CONSTRUCTION	67
6.1	GENERAL	67
6.2	CONSTRUCTION SUPERVISION AND CONSIDERATIONS	67
6.2.1	General	67
6.2.2	Drilling	68
6.2.3	Installation of Soil-nail Reinforcement	73
6.2.4	Grouting	73
6.2.5	Construction of Soil-nail Heads	74
6.2.6	Excavation Sequence	74
6.3	TESTING	75
6.3.1	Material Compliance Testing	75
6.3.2	Pullout Test	75
6.3.3	Creep Test	77
6.3.4	Non-destructive Testing	77
6.3.5	Destructive Testing	79
7.	MONITORING AND MAINTENANCE	81
7.1	GENERAL	81
7.2	MONITORING	81
7.3	MAINTENANCE	81

	Page No.
REFERENCES	83
GLOSSARY OF SYMBOLS	87
GLOSSARY OF TERMS	93

LIST OF TABLES

Table No.		Page No.
4.1	Classification of Soil Aggressivity	30
4.2	Soil Aggressivity Assessment Scheme	31
5.1	Recommended Corrosion Protection Measures for Soil Nails Carrying Transient Loads	39
5.2	Typical Examples of Slope Failures in Each Consequence-to-life Category	41
5.3	Typical Examples of Slope Failures in Each Economic Consequence Category	41
5.4	Recommended Minimum Factor of Safety against Failure for New Soil-nailed Cut Slopes for a Ten-year Return Period Rainfall	42
5.5	Recommended Minimum Factor of Safety against Failure for Existing Cut Slopes Upgraded by Soil Nails for a Ten-year Return Period Rainfall	42
5.6	Recommended Minimum Factor of Safety against Internal Failure of a Soil Nail	42
5.7	Recommended Sizes of Isolated Soil-nail Heads	46
5.8	Recommended Minimum Factor of Safety against External Failure for Existing Retaining Walls Upgraded by Soil Nails for a Ten-year Return Period Rainfall	51
5.9	Recommended Corrosion Protection Measures for Soil Nails Carrying Sustained Loads	63

LIST OF FIGURES

Figure No.		Page No.
2.1	Schematic Diagram of a Soil-nailed Cut Slope	18
3.1	Two-zone Model of a Soil-nailed System	22
3.2	Effect of Soil-nail Inclination on the Mobilisation of Force in a Soil Nail	23
3.3	Effect of Reinforcement Orientation on the Increase in Shear Strength of Reinforced Soil	24
3.4	Schematic Distribution of Tensile Forces along Soil Nails	25
5.1	Potential External Failure Modes of a Soil-nailed System	34
5.2	Potential Internal Failure Modes of a Soil-nailed System	35
5.3	Typical Details of Class 1 Corrosion Protection Measures	39
5.4	Soil-nail Head Design Method Recommended by the UK Department of Transport	47
5.5	Typical Reinforcement Details of a Soil-nail Head	47
5.6	Typical Details of a Soil-nail Head for a Gentle Slope	48
5.7	Calculation Models for Checking against Sliding, Overturning and Bearing Capacity Failure of a Soil-nailed Retaining Wall	53
5.8	Typical Details of an Exposed Isolated Soil-nail Head for a Concrete Retaining Wall	54
5.9	Typical Details of an Exposed Tie Beam	54
5.10	Typical Connection Details of a Skin Wall	55
5.11	Typical Details of a Recessed Soil-nail Head	62
6.1	Sample Checklist for Soil Nail Construction Control	69
6.2	Set-up for a Pullout Test	76

Figure No.		Page No.
6.3	Typical Procedures and Acceptance Criteria for a Pullout Test	78
6.4	Typical Procedures and Acceptance Criteria for a Creep Test	79

1. INTRODUCTION

1.1 PURPOSE AND SCOPE

The purpose of this Geoguide is to recommend a standard of good practice for the design, construction, monitoring and maintenance of soil-nailed systems in Hong Kong. The document is aimed at professionally qualified engineers who are conversant with the relevant geotechnical engineering principles and procedures.

Soil nailing is an insitu soil reinforcement technique used for enhancing the stability of slopes, retaining walls and excavations. The technique involves installation of closely spaced, relatively slender structural elements, i.e., soil nails, into the ground to stabilise the soil mass. A soil-nailed system is a slope, a retaining wall or an excavation reinforced by soil nails. The geotechnical standards set out in this Geoguide are primarily for the use of high yield deformed steel bars installed by the drill-and-grout method for reinforcing soil cut slopes, retaining walls, fill slopes, excavations, disturbed terrain and natural hillsides. This Geoguide does not cover the use of prestressed soil nails nor the use of soil nails in tunnels, caverns and river banks.

General considerations relating to the potential areas of application, installation methods, basic elements of a soil-nailed system, as well as the merits and limitations of the soil nailing technique are given in [Chapter 2](#). The concept and principles of a soil-nailed system, together with the factors that may affect the behaviour of the system, are presented in [Chapter 3](#).

Guidance on the site investigation and testing specific to the use of soil nails is given in [Chapter 4](#). Guidance on the design of a soil-nailed system, including aesthetics and landscape treatment, is delineated in [Chapter 5](#).

As with other forms of slope engineering works, adequate site supervision and control should be exercised during the construction of soil nails. Regular inspections and proper maintenance should be provided throughout the design life of a soil-nailed system. Where necessary, soil-nailed systems should be monitored during and after construction. Guidance on these aspects is given in [Chapters 6 and 7](#).

The specific meanings of a few selected terms used in this Geoguide are given in the Glossary of Terms at the end of this document.

2. APPLICATIONS

2.1 GENERAL

This Chapter gives an overview of the development and applications of the soil nailing technique in Hong Kong. The basic elements of a soil-nailed system, as well as the merits and the limitations of the technique, are highlighted.

2.2 DEVELOPMENT OF THE SOIL NAILING TECHNIQUE

The soil nailing technique was developed in the early 1960s, partly from the techniques for rock bolting and multi-anchorage systems, and partly from reinforced fill technique (Clouterre, 1991; FHWA, 1998). The New Austrian Tunnelling Method introduced in the early 1960s was the premier prototype to use steel bars and shotcrete to reinforce the ground. With the increasing use of the technique, semi-empirical designs for soil nailing began to evolve in the early 1970s. The first systematic research on soil nailing, involving both model tests and full-scale field tests, was carried out in Germany in the mid-1970s. Subsequent development work was initiated in France and the United States in the early 1990s. The result of this research and development work formed the basis for the formulation of the design and construction approach for the soil nailing technique in the subsequent decades.

The soil nailing technique was introduced to Hong Kong in the 1980s. Soil nailing was first used in Hong Kong as a prescriptive method to provide support to deeply weathered zones in otherwise sound material. This was followed by a few cases where passive anchors or tie-back systems were used. Some of the impetus for these early cases came no doubt from the desire to find an alternative to prestressed ground anchors, which require long-term monitoring. In the mid-1980s a small number of soil-nailed supports to temporary cuts were made. In the early 1990s, the experience of design and construction of soil nails was summarised by Watkins & Powell (1992), which soon became the standard practice in Hong Kong.

Along with the increasing number of existing slopes and retaining walls upgraded by the Government and private owners, the soil nailing technique has gained popularity since the mid-1990s. Nowadays, soil nailing is the most common slope stabilising method in Hong Kong. More than 200 slopes and retaining walls are upgraded using soil nails each year.

2.3 AREAS OF APPLICATION

Given that some subtle adverse geological features could be missed by ground investigation, robust design solutions that are less sensitive to local adverse ground and groundwater conditions (in contrast to solutions without positive support or slope reinforcement) are recommended. Large unsupported cuts, particularly those with significant consequence-to-life or major economic consequence in the event of slope failure, should be avoided as far as practicable. Due to lack of robustness, such cut slopes are especially vulnerable to undetected adverse ground and groundwater conditions. Positive

slope support or reinforcement systems, supplemented with surface and subsurface drainage measures where necessary, are generally preferred to cutting back alone even though the calculated factors of safety of different schemes based on conventional limit equilibrium analysis may be the same.

A soil-nailed system can override local weaknesses in the ground through stress redistribution and is less vulnerable than unsupported cuts to undetected adverse ground and groundwater conditions that have not been accounted for in the slope stability analysis. In Hong Kong, most soil nailing works are associated with the stabilisation of existing soil cut slopes and retaining walls. They are also used for reinforcing new soil cut slopes, existing fill slopes, disturbed terrain and natural hillsides. The use of soil nails in new retaining walls and new fill slopes is rare in Hong Kong. Apart from permanent works, soil nails may be used in temporary excavations.

2.4 FUNDAMENTALS OF A SOIL-NAILED SYSTEM

2.4.1 Installation Methods

There are a variety of soil nail installation methods. The choice of installation method depends on a number of factors such as cost, site access, working space, and ground and groundwater conditions. A brief description of the commonly available soil nail installation methods is given below.

(1) *Drill-and-grout*. This is the most common installation method, both in Hong Kong and overseas. In this method, a soil-nail reinforcement is inserted into a pre-drilled hole, which is then cement-grouted under gravity or low pressure. Various drilling techniques, e.g., rotary, rotary percussive and down-the-hole hammer, are available to suit different ground conditions. The advantage of this method is that it can overcome underground obstructions, e.g., corestones, and the drilling spoil can provide information about the ground. In addition, long soil nails can be installed using the method. The size and alignment of the drillholes can be checked before the insertion of reinforcement, if needed. However, the drill-and-grout method may result in hole collapse. To overcome this problem, casing is required. The drilling and grouting process may also cause disturbance to the ground.

(2) *Self-drilling*. This is a relatively new method when compared with the drill-and-grout method. The soil-nail reinforcement is directly drilled into the ground using a sacrificial drill bit. The reinforcement, which is hollow, serves as both the drill rod and the grout pipe. The installation process is rapid as the drilling and grouting are carried out simultaneously. Instead of using air or water, cement grout is used as the flushing medium, which has the benefit of maintaining hole stability. Centralisers and grout pipes are not needed, and casing is usually not required. However, self-drilling soil nails may not be suitable for the ground containing corestones as they cannot penetrate through rock efficiently. It may be difficult to ensure the alignment of long soil nails due to the flexibility of reinforcement. Durability may also be a concern if it relies on the integrity of the corrosion protection measures in the form of grout cover and corrosion protective coatings to steel reinforcement. This is because the specified minimum grout cover may not be achieved in the absence of centralisers and the corrosion protective coatings could be damaged during

installation. Non-corrodible reinforcement may be explored to overcome the durability problem.

(3) *Driven*. Soil-nail reinforcement is directly driven into the ground by the ballistic method using a compressed air launcher, by the percussive method using hammering equipment, or by the vibratory method using a vibrator. During the driving process, the ground around the reinforcement will be displaced and compressed. The installation process is rapid and it causes minimal ground disruption. However, due to the limited power of the equipment, this method can only be used to install soil nails of relatively short length. Moreover, the soil-nail reinforcement may be damaged by the excessive buckling stress induced during the installation process, and hence it is not suitable for sites that contain stiff soil or corestones. As the soil-nail reinforcement is in direct contact with the ground, it is susceptible to corrosion unless non-corrodible reinforcement is used.

2.4.2 Basic Elements of a Soil-nailed System

Figure 2.1 shows the cross-section of a typical soil-nailed cut slope. A soil-nailed system formed by the drill-and-grout method comprises the following basic elements:

(1) *Soil-nail Reinforcement*. A soil-nail reinforcement is the main element of a soil-nailed system. Its primary function is to provide tensile resistance. The reinforcement is typically a solid high yield deformed steel bar. Other types of materials, such as fibre reinforced polymer, can also be used as a soil-nail reinforcement.

(2) *Reinforcement Connector (Coupler)*. Couplers are used for joining sections of soil-nail reinforcing bars.

(3) *Cement Grout Sleeve*. Cement grout, made of Portland cement and water, is placed in a pre-drilled hole after the insertion of a soil-nail reinforcement. The cement grout sleeve serves the primary function of transferring stresses between the ground and the soil-nail reinforcement. It also provides a nominal level of corrosion protection to the reinforcement.

(4) *Corrosion Protection Measures*. Different types of corrosion protection measures are required depending on the design life and soil aggressivity. Common types of corrosion protection measures are hot-dip galvanising and corrugated plastic sheathing. Heat-shrinkable sleeves made of polyethylene and anti-corrosion mastic sealant material are commonly used to protect couplers.

(5) *Soil-nail Head*. A soil-nail head typically comprises a reinforced concrete pad, a steel bearing plate and nuts. Its primary function is to provide a reaction for individual soil nails to mobilise tensile force. It also promotes local stability of the ground near the slope surface and between soil nails.

(6) *Slope Facing*. A slope facing generally serves to provide the slope with surface protection, and to minimise erosion and other adverse effects of surface water on the slope. It may be soft, flexible, hard, or a combination of the three (CIRIA, 2005). A soft slope facing is non-structural, whereas a flexible or hard slope facing can be either structural or

non-structural. A structural slope facing can enhance the stability of a soil-nailed system by the transfer of loads from the free surface in between the soil-nail heads to the soil nails and redistribution of forces between soil nails. The most common type of soft facing is vegetation cover, often in association with an erosion control mat and a steel wire mesh. Some proprietary products of flexible facing are available. Hard facing includes sprayed concrete, reinforced concrete and stone pitching. Structural beams and grillages can also be constructed on the slope surface to connect the soil-nail heads together to promote the integral action of the soil-nailed system.

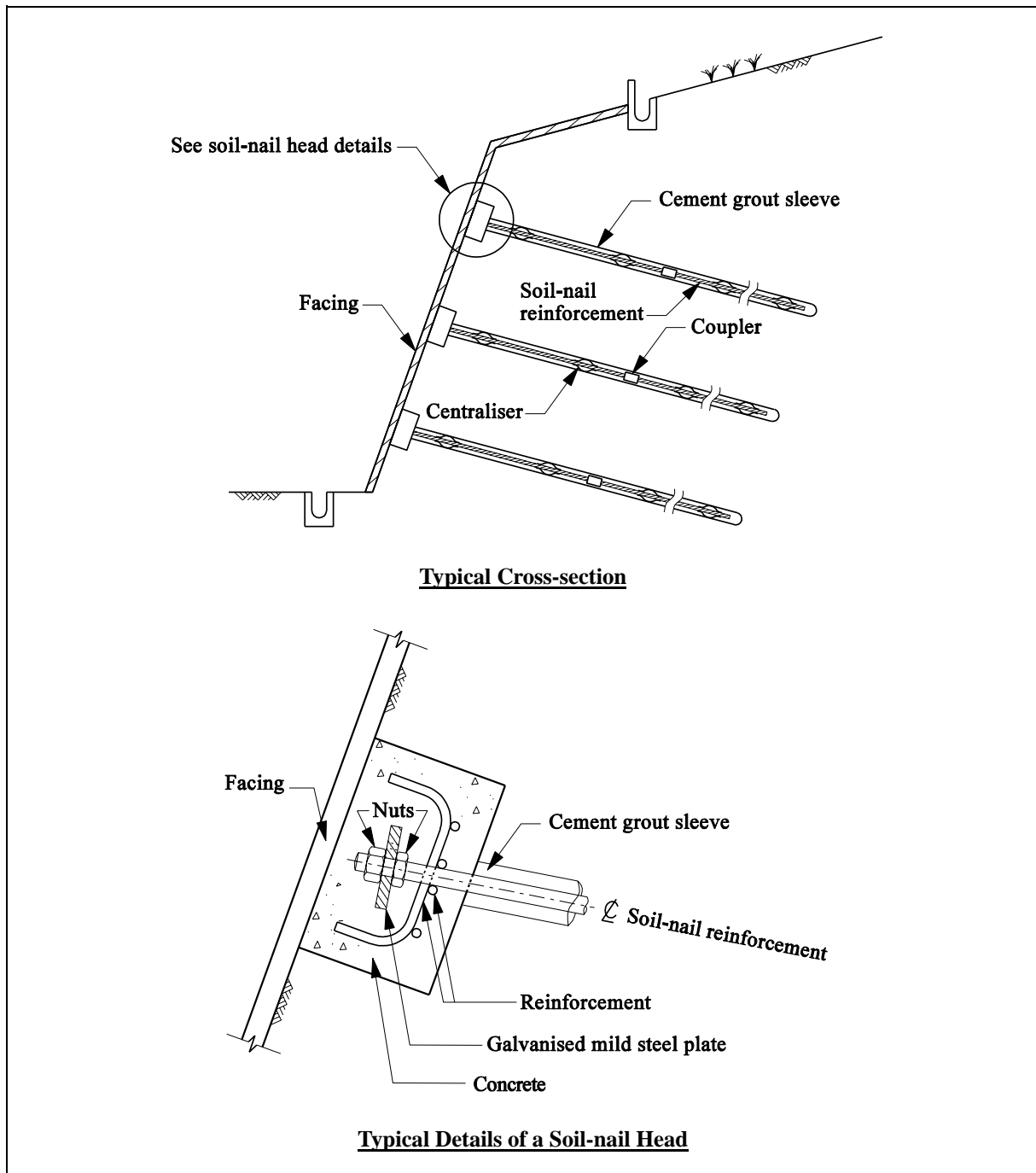

Figure 2.1 Schematic Diagram of a Soil-nailed Cut Slope

2.5 MERITS AND LIMITATIONS

The soil nailing technique offers an alternative design solution to the conventional techniques of cutting back and retaining wall construction. The following are typical merits of adopting the soil nailing technique in respect of construction, cost and performance:

- (a) It is suitable for cramped sites with difficult access because the construction plant required for soil nail installation is small and mobile.
- (b) It can easily cope with site constraints and variations in ground conditions encountered during construction, e.g., by adjusting the location and length of the soil nails to suit the site conditions.
- (c) During construction, it causes less environmental impact than cutting back and retaining wall construction as no major earthworks and tree felling are needed.
- (d) There could be time and cost savings compared to conventional techniques of cutting back and retaining wall construction which usually involve substantial earthworks and temporary works.
- (e) It is less sensitive to undetected adverse geological features, and thus more robust and reliable than unsupported cuts. In addition, it renders higher system redundancy than unsupported cuts or anchored slopes due to the presence of a large number of soil nails.
- (f) The failure mode of a soil-nailed system is likely to be ductile, thus providing warning signs before failure.

The soil nailing technique has the following main limitations:

- (a) The presence of utilities, underground structures or other buried obstructions poses restrictions to the length and layout of soil nails.
- (b) The zone occupied by soil nails is sterilised and the site poses constraints to future development.
- (c) Permission has to be obtained from the owners of the adjacent land for the installation of soil nails beyond the lot boundary. This places restrictions on the layout of soil nails.
- (d) The presence of high groundwater levels may lead to construction difficulties in hole drilling and grouting, and

instability problems of slope surface in the case of soil-nailed excavations.

- (e) The effectiveness of soil nails may be compromised at sites with past large landslides involving deep-seated failure due to disturbance of the ground.
- (f) The presence of permeable ground, such as ground with many cobbles, boulders, highly fractured rocks, open joints, or voids, presents construction difficulties due to potential grout leakage problems.
- (g) The presence of ground with a high content of fines may lead to problems of creeping between the ground and soil nails.
- (h) Long soil nails are difficult to install, and thus the soil nailing technique may not be appropriate for deep-seated landslides and large slopes.
- (i) Because soil nails are not prestressed, mobilisation of soil-nail forces will be accompanied by ground deformation. The effects on nearby structures, facilities or services may have to be considered, particularly in the case of soil-nailed excavations.
- (j) Soil nails are not effective in stabilising localised steep slope profiles, back scarps, overhangs or in areas of high erosion potential. Suitable measures, e.g., local trimming, should be considered prior to soil nail installation.

The merits and limitations of the soil nailing technique listed above are not exhaustive. Designers should exercise due engineering judgement in option assessments to select the best design solution.

3. PRINCIPLES OF A SOIL-NAILED SYSTEM

3.1 GENERAL

This Chapter gives a general description of the principles of a soil-nailed system and highlights the key factors that may affect the behaviour of the system.

3.2 CLASSIFICATION OF A SOIL-NAILED SYSTEM

In the context of this Geoguide, a soil-nailed system is considered as a soil-nailed retaining wall if the facing of the system is sub-vertical, and it is designed to perform as a structural member that provides retention action to the ground by virtue of its self-weight, bending strength or stiffness. For example, if soil nails are installed into a gravity, reinforced concrete or cantilevered retaining wall, the system is considered as a soil-nailed retaining wall. On the contrary, if the facing serves mainly the function of surface protection or connection between individual soil nails, such as a sprayed concrete facing, the system should be regarded as a soil-nailed slope. Also, in this document, a soil-nailed system is considered to be a soil-nailed excavation if the reinforcing bars in an excavation, which carry either transient or sustained loads, are designed to perform as soil nails.

3.3 FUNDAMENTAL MECHANISM OF A SOIL-NAILED SYSTEM

The soil nailing technique improves the stability of slopes, retaining walls and excavations principally through the mobilisation of tension in the soil nails. The tensile forces are developed in the soil nails primarily through the frictional interaction between the soil nails and the ground as well as the reactions provided by soil-nail heads/facing (Figure 3.1). The tensile forces in the soil nails reinforce the ground by directly supporting some of the applied shear loadings and by increasing the normal stresses in the soil on the potential failure surface, thereby allowing higher shearing resistance to be mobilised. Soil-nail heads and the facing also provide a confinement effect by limiting the ground deformation close to normal to the slope surface. As a result, the mean effective stress and the shearing resistance of the soil behind the soil-nail heads will increase. They also help to prevent local failures near the surface of a slope, and to promote an integral action of the reinforced soil mass through the redistribution of forces among soil nails. The resistance against pullout failure of the soil nails is provided by the part of soil nail that is embedded into the ground behind the potential failure surface.

The internal stability of a soil-nailed system is usually assessed using a two-zone model, namely the active zone and the passive zone (or resistant zone), which are separated by a potential failure surface (Figure 3.1). The active zone is the region in front of the potential failure surface, where it has a tendency to detach from the soil-nailed system. The passive zone is the region behind the potential failure surface, where it remains more or less intact. The soil nails act to tie the active zone to the passive zone.

Designers should caution that the two-zone configuration is only a simplified model for limit equilibrium analysis where the deformation of a soil-nailed system is not accounted

for. In reality, in a soil slope for example, unless the failure is dictated by joint settings where the failure surface is distinct, there is generally a shearing zone subject to shear distortion. The nail-ground interaction is complex, and the forces developed in the soil nails are influenced by many factors. These factors include the mechanical properties of the soil nails (i.e., tensile strength, shear strength and bending capacity), the inclination and orientation of the soil nails, the shear strength of the ground, the relative stiffness of the soil nails and the ground, the friction between the soil nails and the ground, the size of soil-nail heads and the nature of the slope facing.

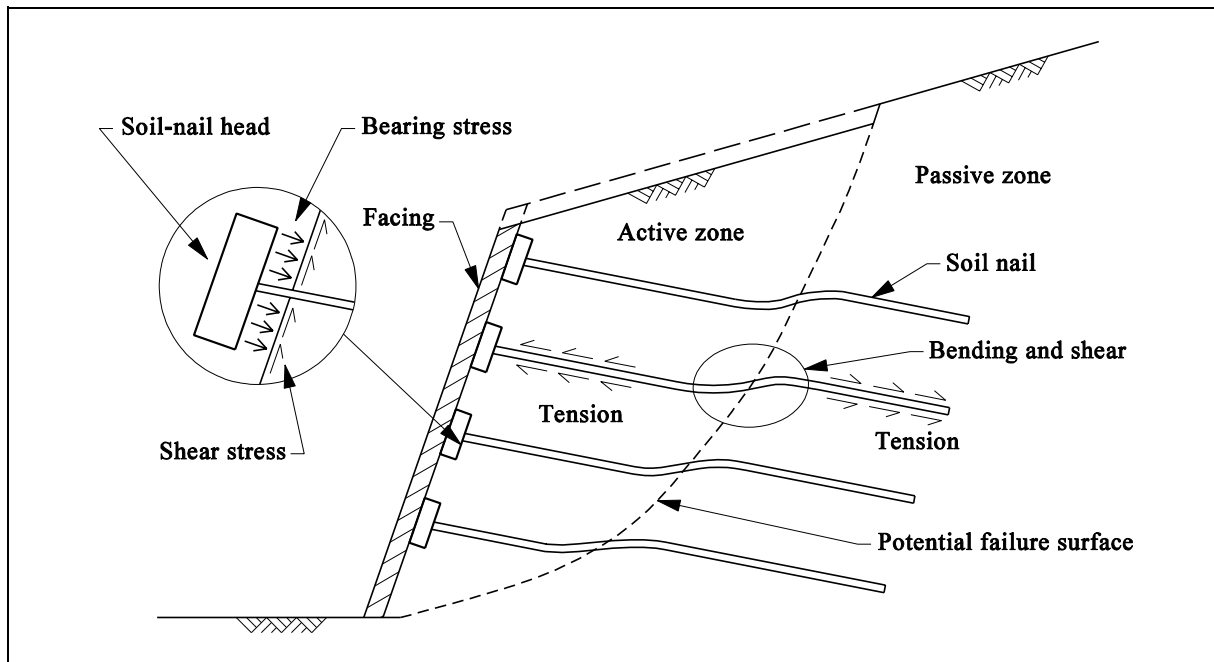

Figure 3.1 Two-zone Model of a Soil-nailed System

3.4 NAIL-GROUND INTERACTION

In the active zone, forces are developed in soil nails through interaction between the ground, the soil nails, the soil-nail heads and the slope facing (Figure 3.1). There are two fundamental mechanisms of nail-ground interaction, namely (i) the nail-ground friction that leads to the development of axial tension or compression in the soil nails, and (ii) the soil bearing stress on the soil nails and the nail-ground friction on the sides of soil nails that lead to the development of shear and bending moments in the soil nails.

If the soil nails are aligned close to the direction of the maximum tensile strain of the soil, the action in the soil nails is primarily tension, which is developed through the mechanism of nail-ground friction. Shear stresses and bending moments are developed in the soil nails through the mechanism of soil bearing stresses as well as the nail-ground friction at the sides of soil nails. In a homogeneous and isotropic soil mass, the mobilisation of shear stresses and bending moments of soil nails are small under service load conditions (Jewell & Pedley, 1992). In contrast, if the soil nails are aligned in the direction of compressive strain in the soil, compressive forces will be developed in the soil nails. This can lead to a decrease in normal stresses in the soil on the potential failure surface, which reduces the

shearing resistance of the reinforced soil mass. If the soil nails are aligned in the direction of zero axial strain, they will be subject to shear and bending only. However, due to relatively slender dimensions of the soil nails, these reinforcing contributions are limited by the small flexural strength, and they are usually negligible (Jewell & Pedley, 1992; FHWA, 1998).

The above principles explain the effect of the soil-nail inclination on the mobilisation of forces in soil nails. In general, the effectiveness of a soil nail in mobilising tensile force decreases as the inclination of the soil nail to the horizontal, α_s , as indicated in Figure 3.2, increases. For most soils, where the soil nails are sub-horizontally inclined, the minimum deformation required to mobilise the full bending and shear resistance of a soil nail is about one order of magnitude greater than that required to mobilise the full tensile strength, and hence the primary action of the soil nails is in tension (Clouterre, 1991; FHWA, 1998). If the soil nails are steeply inclined, the effectiveness of the soil nails will be reduced significantly as some of the soil nails may be in compression. Therefore, steeply inclined soil nails should be used with caution. Figure 3.3 shows the effect of reinforcement orientation on the shear strength of the reinforced soil.

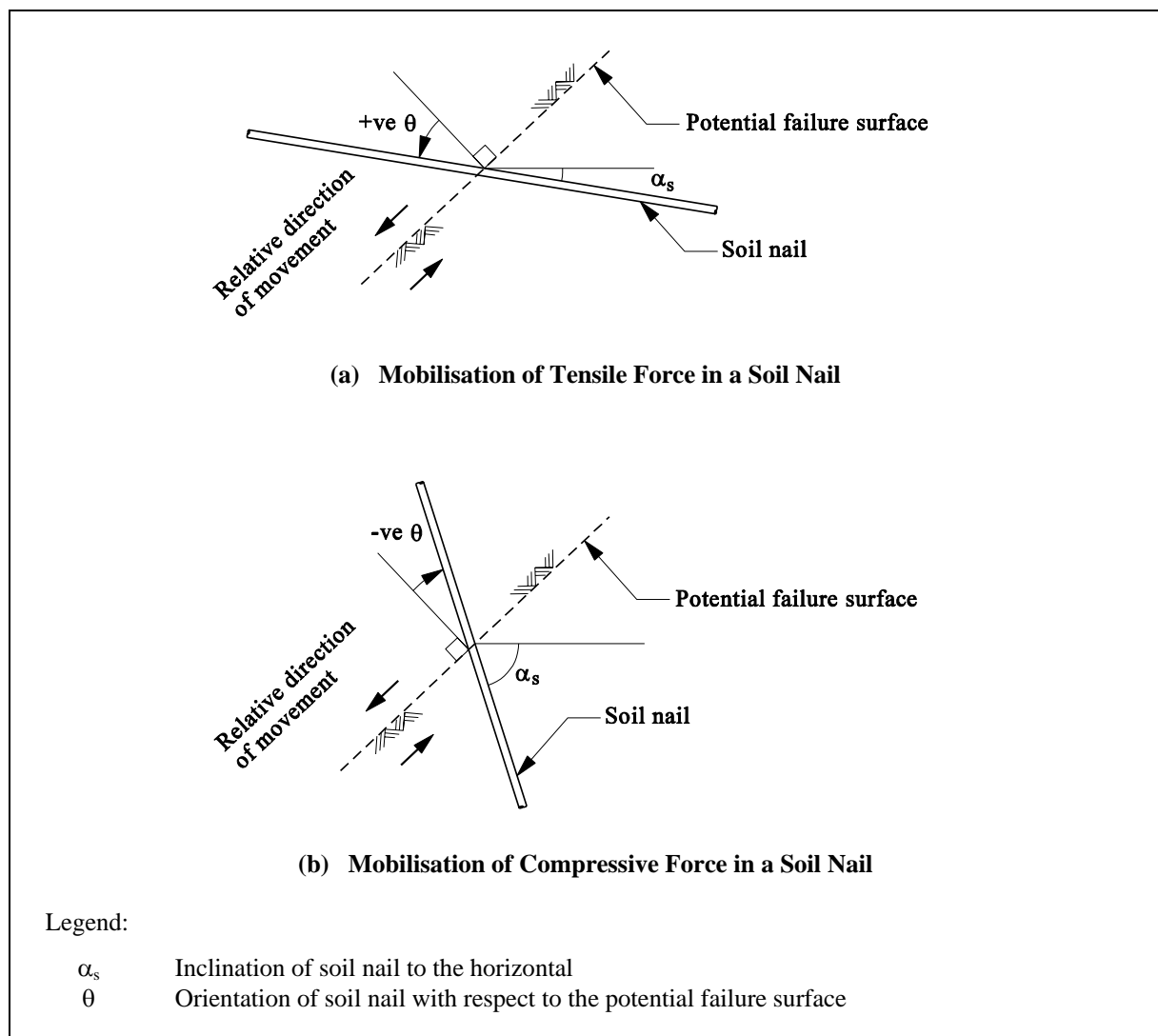

Figure 3.2 Effect of Soil-nail Inclination on the Mobilisation of Force in a Soil Nail

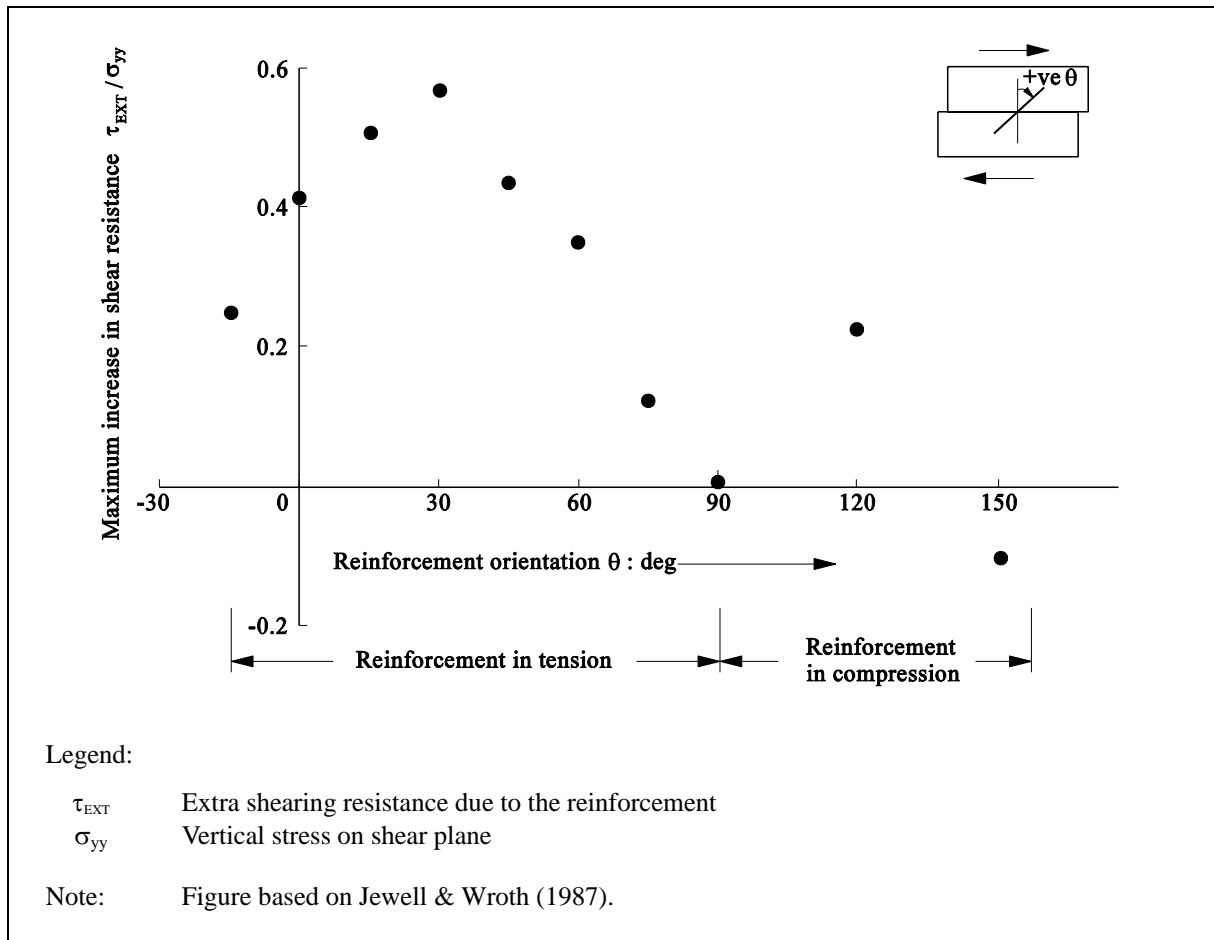

Figure 3.3 Effect of Reinforcement Orientation on the Increase in Shear Strength of Reinforced Soil

Compressive and shear strains are developed in the soil beneath a soil-nail head in response to the ground deformation in the active zone (Figure 3.1). If the resultant strain is close to the direction perpendicular to the base of soil-nail head, the head-ground interaction will be dominantly in the form of a bearing mechanism. However, if the resultant strain is in a direction that deviates significantly from the normal to the base of the soil-nail head, the head-ground interaction will be a combination of bearing and sliding mechanisms. In this case, the effectiveness of the soil-nail head in mobilising tensile force in the soil nail will be reduced.

The soil nails and soil-nail heads/facing act together to tie the active zone to the passive zone. The interaction between soil-nail heads and the ground, particularly the bearing mechanism, gives rise to tensile loads at the heads of soil nails. The tensile loads at the soil-nail heads are taken up by the soil-nail reinforcement. The tensile force in a soil nail increases as the size of the soil-nail head or the coverage of facing increases.

The passive zone behind the potential failure surface contains the distal end of the soil nails with sufficient bond length to prevent the soil nails from being pulled out. When there is ground deformation in the active zone, pullout forces are induced in the soil nails in the passive zone (Figure 3.1). Through the mobilisation of bond stresses between the ground and the cement grout sleeve, and between the cement grout sleeve and the soil-nail

reinforcement, the pullout force is transferred between the soil-nail reinforcement and the ground. The force that can be developed in a soil nail is limited by the bond stresses that can be mobilised between the ground and the cement grout sleeve, and between the cement grout sleeve and the soil-nail reinforcement.

Theoretically, the bond strength between the cement grout sleeve and the ground depends on the contact stress and the interface coefficient of friction between the cement grout sleeve and the ground. The process of drilling reduces significantly the radial stress at the circumference of the drillhole. In reality, the drillhole face, which is commonly formed by percussive drilling in Hong Kong, is fairly irregular and rough. Apart from friction, the mechanical interlocking between the cement grout sleeve and the ground contributes a significant portion of the bond strength. Upon pulling of the soil nail, shearing may occur within the ground mass in a finite zone surrounding the soil nail. If the soil is dilative, the effect of restrained soil dilatancy will come into play. The effect of this can be significant and can lead to high friction between the soil nail and the ground.

The distribution of bond stress between the cement grout sleeve and the ground along a soil nail is not uniform. Figure 3.4 presents a schematic distribution of the locus of maximum tensile forces of soil nails and the potential failure surface of a slope. The point of maximum tension in a soil nail is close to, but does not necessary occur at the point of maximum soil shear strain, i.e., the potential failure surface of a slope (FHWA, 2003).

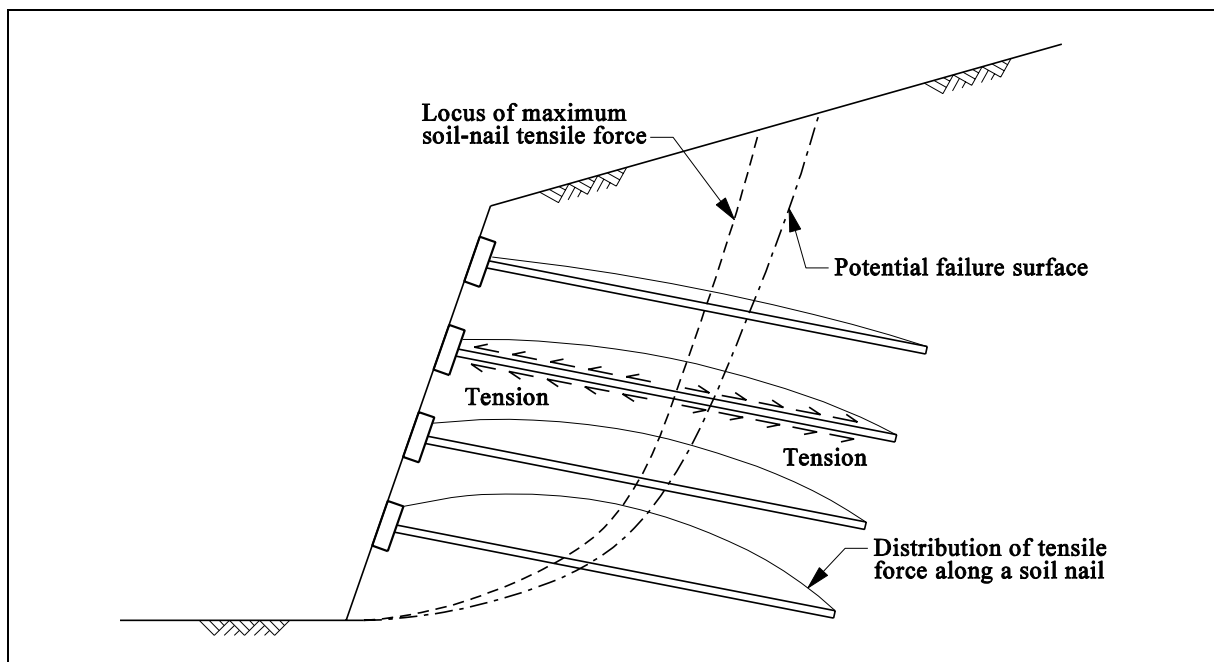

Figure 3.4 Schematic Distribution of Tensile Forces along Soil Nails

Designers should take into account the interaction between soil nails and the ground in the design of a soil-nailed system. As the nail-ground interaction is affected by the mechanical properties of the soil nail including stiffness, ductility and strength, the experience gained in the use of steel soil nails may not be applicable to the use of other types of reinforcement materials.

4. SITE INVESTIGATION AND TESTING

4.1 GENERAL

In general, the site investigation and testing for soil-nailed systems are similar to those for un-reinforced slopes, which normally proceed in stages, via (i) desk study, (ii) site reconnaissance, (iii) collection of field data including ground investigation and laboratory testing, and (iv) follow-up investigation and design review during construction. General guidance on the planning of site investigation and on the execution of ground investigation is given in Geoguide 2 : Guide to Site Investigation (GCO, 1987). Guidance on the description of rocks and soils for engineering purposes is provided in Geoguide 3 : Guide to Rock and Soil Descriptions (GCO, 1988). Guidance on laboratory testing of soil is given in Geospec 3 : Model Specification for Soil Testing (GEO, 2001). Reference should also be made to the Highway Slope Manual (GEO, 2000a) for guidance on site investigation for highway slopes, and to GEO Publication No. 1/2007 : Engineering Geological Practice in Hong Kong (GEO, 2007a) for guidance on engineering geological practice and when specialist engineering geological expertise should be sought. This Chapter gives guidance on the site investigation and testing specific to assessing the buildability and durability of soil nails.

4.2 BUILDABILITY OF SOIL NAILS

In designing soil nails, designers should give due consideration to the buildability of the soil nails to ensure that the design is practical and buildable.

The buildability of soil nails is to a large extent governed by the ground and groundwater conditions. Some ground conditions are more likely to present problems for soil nail construction. For example, the chance of encountering problems of excessive grout leak during soil nail installation is high if the geological conditions comprise generally permeable coarse materials with a relatively low silt/clay content in the matrix and moderate to high intergranular porosity, or if geological structures are present that enable enhanced fluid through-flow. The following geological conditions are susceptible to excessive grout leak during soil nail installation:

- (a) fill, containing a significant proportion of coarse materials, i.e., boulders, cobbles, gravel and sand,
- (b) colluvium and fluvial deposits with a high proportion of coarse materials,
- (c) erosion pipes that may be partly infilled by porous and permeable materials,
- (d) material boundaries within colluvium, and between colluvium and insitu materials, and within corestone-bearing saprolite, especially at the margins of corestones, open joints, faults and shear zones, and other discontinuities (e.g., zones of hydrothermal alternation, etc.) that are weathered and

eroded, and so are open,

- (e) landslide scars, tension cracks and other features related to slope deformation, as these may include voids within transported and insitu materials, and
- (f) drainage lines intersecting slopes, within which colluvium may be present, erosion pipes may be developed, and preferred groundwater through-flow indicated by seepage locations/horizons may also occur.

The leaked grout could permeate into voids present in the ground and dam up the groundwater in the vicinity of the soil-nailed system. Sufficient information about the ground and groundwater conditions should be collected for assessing the buildability of a soil-nailed system. This information also provides the basis for the formulation of models for the design of a soil-nailed system. Guidance on the formulation of appropriate design models and design groundwater conditions is given in [Section 5.3.3](#). If there is concern about the damming up of groundwater due to soil nail construction, piezometers should be installed in appropriate locations and monitored for a considerable time to ascertain the damming effect.

Drilling for long soil nails, typically over 20 m, stands a higher chance of intersecting groundwater tables and adverse geological features such as local weak geological zones and seams, and dykes of high hydraulic conductivity contrast. This may lead to construction problems such as collapses of soil or rock fragments along the drillhole and large amounts of grout leak, which in turn affect the quality of soil nails. For cases where long or closely-spaced soil nails are proposed, or where the ground or groundwater conditions are likely to be adverse to soil nail construction, designers should consider undertaking an assessment of buildability and the effects of soil nail installation on the existing ground and groundwater conditions. This may include a site trial prior to carrying out the soil nailing works. By suitably positioning the trial soil nails, the site trial can provide information on potential construction problems such as areas of potential excessive grout leak, loose materials prone to hole collapse and high groundwater levels. This information is important for assessing the buildability of soil nailing works. It also allows for better design of working soil nails, and planning of appropriate measures to overcome the possible site problems. Details of the trial, including its locations, potential problems and contingency measures if the trial soil nails fail, should be included in the designer's requirements under the contract.

Field pullout tests may be carried out as part of the site trial to provide early information on the pullout resistance. Details of pullout tests are given in [Section 6.3.2](#). If pullout tests are conducted during ground investigation, the number of pullout tests to be carried out during construction works may be reduced suitably. However, they should not replace entirely the pullout tests during the construction stage as the latter are also a trial on the adequacy of the construction plant and labour skill for deploying specific construction works.

It is important to have a thorough understanding and appreciation of the geological and hydrogeological conditions of a site in order to assess the buildability of soil nails. The site investigation should be sufficiently detailed to affirm the buildability of soil nailing works and

to obtain information for design. It should not be confined to the ground in which the soil nails are to be installed; the ground mass in the vicinity of the soil-nailed system that will affect the overall stability and deformation of the proposed soil-nailed system should also be investigated.

4.3 DURABILITY OF SOIL NAILS

4.3.1 General

Corrosion of steel reinforcement reduces the durability of a soil-nailed system. Different ground conditions pose different degrees of corrosion potential to soil nails. It is important to appreciate the aggressivity of the soil at a site in order to provide appropriate corrosion protection measures to the soil nails. The aggressivity of soils can vary over a wide range because of the great variety of soil compositions and properties, and other environmental factors.

In general, the corrosion rate of steel soil nails is affected by the physical and chemical characteristics of the soil where the soil nails are embedded. The physical characteristics are those that control the permeability of the soil for the passage of air and water. Fine-grained soils, i.e., silts and clays, are potentially more corrosive than coarse-grained soils, i.e., sands and gravels, in which there is a greater circulation of air and less water-retention capacity. The chemical characteristics are those that determine the ability of the soil to act as an electrolyte for the development of local corrosion cells. They include alkalinity, acidity, concentrations of oxygen and dissolved salts, and organic matter and bacteria content.

4.3.2 Soil Aggressivity

The aggressivity of the soil at a site can be assessed from the site setting, development history and the nature and extent of utilities affecting the site. The soil at a site should be regarded as “aggressive” if,

- (a) the site has been, or is likely to be, affected by leakage or discharge of fluids from old developments (e.g., village house and squatter hut), sewage treatment systems (e.g., septic tank and soak-away pit), industrial facilities (e.g., petrol station and chemical plant), livestock facilities (e.g., animal farm and slaughter house), or cultivated land, or
- (b) the site shows signs of seepage (leakage) from nearby water-carrying services, e.g., salt water main, fresh water main and sewer, or
- (c) the site is in the vicinity of the sources of stray current such as from an electricity substation, electrified rail system and tramway system.

The soil at a site may be classified as “non-aggressive” if,

- (a) the site has not been, and is unlikely to be, affected by the leakage or discharge of fluids from developments or water-carrying services, e.g., the uphill side of the site being purely natural terrain, and
- (b) the site shows no signs of seepage or high groundwater levels that could bring corrosive agents from a distance into contact with the soil nails.

Otherwise, the soil at a site should be classified as “potentially aggressive”. Examples of this are,

- (a) a site that has the potential of being affected by the leakage or discharge of fluids from developments, public roads, landfill, sewage treatment plant, industrial plant, water-carrying services, etc., and
- (b) a site that shows constant seepage or high groundwater levels, the source of which is uncertain.

For sites with “potentially aggressive” soils or for cases where designers are in doubt, a detailed soil aggressivity assessment should be carried out.

4.3.3 Soil Aggressivity Assessment

A detailed assessment of the soil aggressivity is made by means of laboratory physical and chemical testing, review of site records and field observations. The assessment is based on a marking system developed by Eyre & Lewis (1987) with modifications to suit local conditions. In this system, soil aggressivity is classified into four categories as shown in [Table 4.1](#). The classification is based on the total mark determined from the soil aggressivity assessment scheme given in [Table 4.2](#). The total mark of a soil specimen is equal to the sum of individual marks assigned to each component parameters listed in the scheme.

Table 4.1 Classification of Soil Aggressivity

Classification of Soil Aggressivity	Total Mark from the Soil Aggressivity Assessment Scheme
Non-aggressive	≥ 0
Mildly aggressive	- 1 to - 4
Aggressive	- 5 to - 10
Highly aggressive	$\leq - 11$

Table 4.2 Soil Aggressivity Assessment Scheme

Property	Measured Value	Mark	Test Method
Soil Composition	Fraction passing 63 μm sieve $\leq 10\%$, and PI of fraction passing 425 μm sieve < 2 , and Organic content $< 1.0\%$	2	Geospec 3 Test Methods 6.1, 8.1, 8.2, 8.5, 8.6 and 9.1 (GEO, 2001)
	$10\% <$ Fraction passing 63 μm sieve $\leq 75\%$, and Fraction passing 2 μm sieve $\leq 10\%$, and PI of fraction passing 425 μm sieve < 6 , and Organic content $< 1.0\%$	0	
	Any grading, and PI of fraction passing 425 μm sieve < 15 , and Organic content $< 1.0\%$	- 2	
	Any grading, and PI of fraction passing 425 μm sieve ≥ 15 and Organic content $< 1.0\%$	- 4	
	Any grading, and Organic content $\geq 1.0\%$	- 4	
Resistivity (ohm-cm)	$\geq 10,000$	0	BS 1377: Part 3: 1990, Test 10.4 (BSI, 1990)
	$< 10,000$ but $\geq 3,000$	- 1	
	$< 3,000$ but $\geq 1,000$	- 2	
	$< 1,000$ but ≥ 100	- 3	
	< 100	- 4	
Moisture Content	$\leq 20\%$	0	Geospec 3 Test Method 5.2 (GEO, 2001)
	$> 20\%$	- 1	
Groundwater Level	Above groundwater level and no periodic flow or seepage	1	-
	Local zones with periodic flow or seepage	- 1	
	At groundwater level or in zones with constant flow or seepage	- 4	
pH	$6 \leq \text{pH} \leq 9$	0	Geospec 3 Test Method 9.5 (GEO, 2001) (See Note 1)
	$5 \leq \text{pH} < 6$	- 1	
	$4 \leq \text{pH} < 5$ or $10 \geq \text{pH} > 9$	- 2	
	$\text{pH} < 4$ or $\text{pH} > 10$	- 4	
Soluble Sulphate (ppm) (See Note 2)	≤ 200	0	Geospec 3 Test Method 9.3 (GEO, 2001)
	> 200 but ≤ 500	- 1	
	> 500 but $\leq 1,000$	- 2	
	$> 1,000$	- 3	
Made Ground (See Note 3)	None	0	-
	Exist	- 4	
Chloride Ion (ppm)	≤ 100	0	Geospec 3 Test Method 9.4 (GEO, 2001)
	> 100 but ≤ 300	- 1	
	> 300 but ≤ 500	- 2	
	> 500	- 4	

Notes: (1) If pH value is less than 4 or greater than 10, the soil should be classified as aggressive regardless of the results of other test items.
(2) Water soluble sulphate as SO_3 .
(3) "Made ground" refers to man-made ground associated with high corrosion rate such as non-engineering fill with rubbish and organic matters.

Soil that is extremely acidic or strongly alkaline generally results in high rate of steel corrosion. Hence, if the pH value of the soil specimen is found to be less than 4 or greater than 10, the soil should be classified as “aggressive” regardless of the results of other test items.

The guidelines on the provision of corrosion protection measures for soil nails installed in soils of different aggressivity are given in [Section 5.5](#).

5. DESIGN OF A SOIL-NAILED SYSTEM

5.1 GENERAL

This Chapter provides guidance on the design of soil nails that are in the form of solid high yield deformed steel bars installed using the drill-and-grout method without prestressing. The general guidance in [Sections 5.2 to 5.5, 5.10 and 5.11](#) is applicable to any type of soil-nailed system. Specific guidance for the design of soil nails carrying transient loads in soil-nailed slopes, retaining walls and fill slopes that have no sign of continuous ground deformation is given in [Sections 5.6 to 5.8](#) respectively. In these circumstances, the soil-nailed systems do not rely on the soil nails for stability most of the time. An example of transient load is the water force due to a high groundwater level following a heavy rainfall. Additional guidelines on the design of soil nails carrying sustained loads and in other specific circumstances are given in [Section 5.12](#).

5.2 DESIGN CONSIDERATIONS

A soil-nailed system is required to fulfil fundamental requirements of stability, serviceability and durability during construction and throughout its design life. Other issues such as cost and environmental impact are also important design considerations.

(1) *Stability*. The stability of a soil-nailed system throughout its design life should be assessed. Its performance should not exceed a state at which failure mechanisms can form in the ground or within the soil-nailed system, or when movement of the soil-nailed system can lead to severe damage to its structural elements or nearby structures, facilities or services. The design of a soil-nailed system should ensure that there is an adequate safety margin against all the perceived potential modes of failure. Guidance on the design for stability is given in [Section 5.3](#).

(2) *Serviceability*. The performance of a soil-nailed system should not exceed a state at which the movement of the system affects its appearance or the efficient use of nearby structures, facilities or services, which rely upon it. Potential serviceability problems associated with soil-nailed systems include excessive ground deformation, and deterioration of slope facing and drainage systems. Guidance on the design for serviceability is given in [Section 5.4](#).

(3) *Durability*. The environmental conditions should be investigated at the design stage to assess their significance in relation to the durability of soil nails. Appropriate measures should be applied to the soil nails such that an adequate safety margin of the soil-nailed system can be maintained throughout its design life. The durability of a steel soil-nailed system is governed primarily by the resistance to corrosion under different soil aggressivity. Guidance on the design of corrosion protection measures is given in [Section 5.5](#).

(4) *Economic Considerations*. The construction cost of a soil-nailed system depends on the material cost, construction method, temporary works requirements, buildability, corrosion protection requirements, soil-nail layout, type of facing, etc. General guidance on

the buildability of soil nails is given in [Section 4.2](#).

(5) *Environmental Considerations*. The construction of a soil-nailed system may disturb the ground ecosystem, induce nuisance and pollution during construction, and cause visual impact to the existing environment. Adverse impact to the environment should be minimised. For example, mature trees and natural terrain should be preserved and protected whenever possible to sustain the ecosystem. Appropriate pollution control measures, such as providing water sprays and dust traps at the mouths of drillholes when drilling rocks, screening the working platform and installing noise barriers in areas with sensitive receivers, should be provided. Suitable aesthetic and landscape treatment as discussed in [Section 5.11](#) should also be carried out to reduce the visual impact of the works.

5.3 DESIGN FOR STABILITY

5.3.1 General

A soil-nailed system should be designed against instability. The potential modes of failure are discussed in [Section 5.3.2](#). The recommended approach to formulate the ground and groundwater models is delineated in [Section 5.3.3](#). The methods of analysis for assessing the stability of a soil-nailed system are discussed in [Section 5.3.4](#). Two different approaches, namely an analytical approach based on calculation and a prescriptive approach based on experience, are commonly used for the design of soil nails in Hong Kong. Recommended design procedures based on the analytical approach are given in [Sections 5.6](#) to [5.8](#). Guidance related to the prescriptive design is given in [Section 5.9](#).

5.3.2 Modes of Failure

Designers should exercise engineering judgement to identify all potential modes of failure under the specific ground and groundwater conditions, and the type of soil-nailed system. As a minimum, the modes of failure as illustrated in [Figures 5.1](#) and [5.2](#) should be considered in the design of a soil-nailed system. They can be classified broadly as external and internal failure mechanisms.

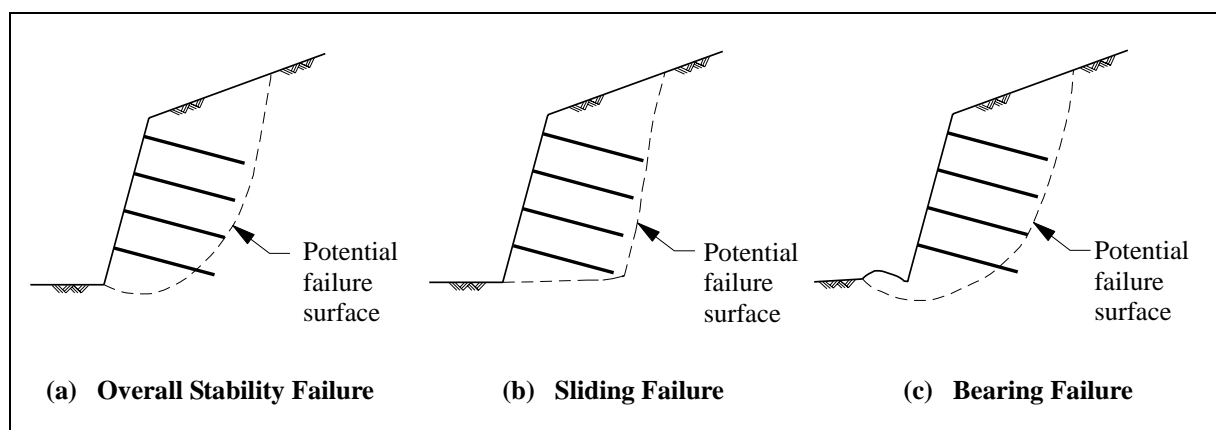

Figure 5.1 Potential External Failure Modes of a Soil-nailed System

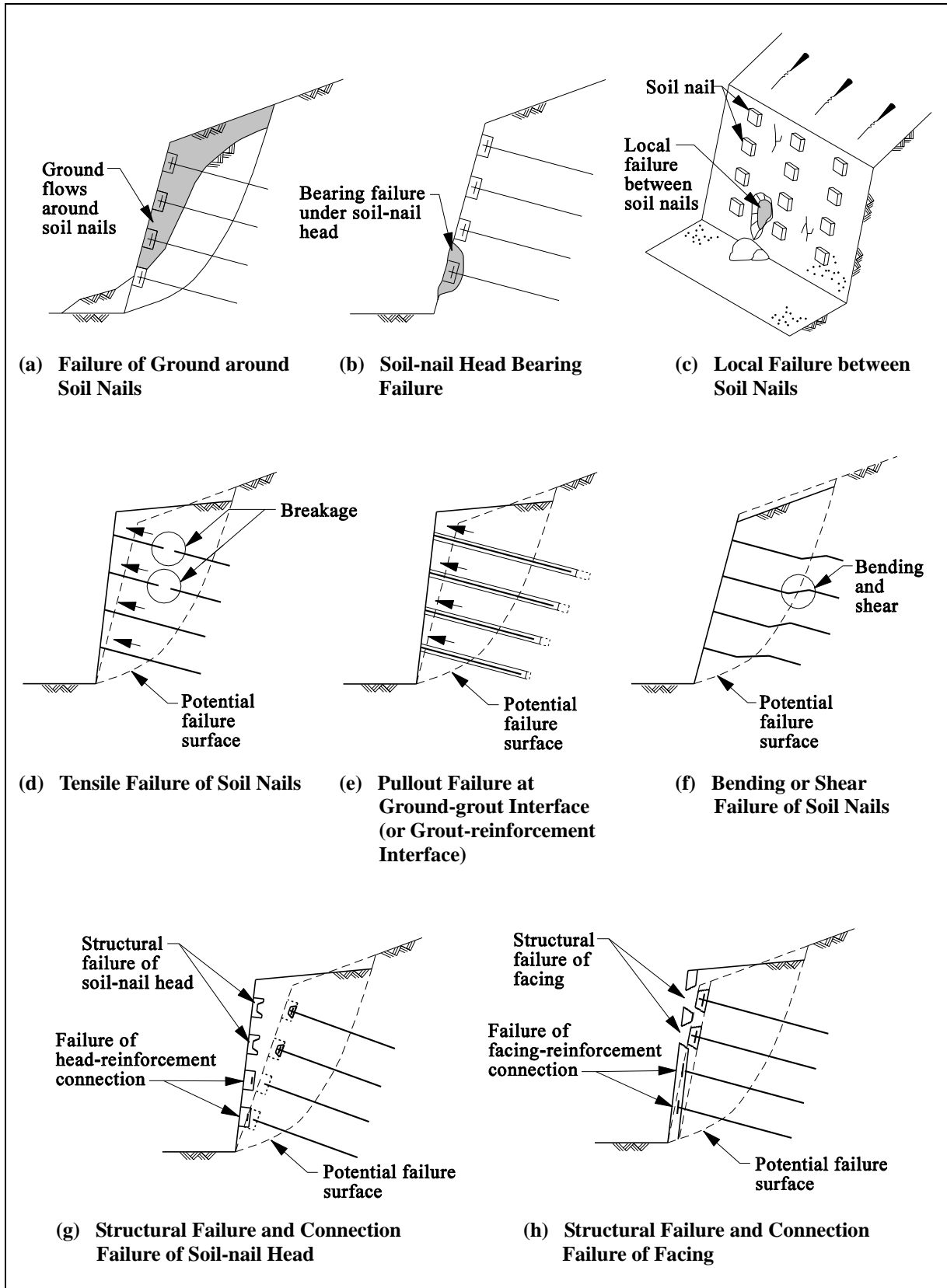

Figure 5.2 Potential Internal Failure Modes of a Soil-nailed System

(1) *External Failure*. External failure refers to the development of potential failure surfaces essentially outside the soil-nailed ground mass. The failure can be in the form of sliding, rotation, bearing, or other forms of loss of overall stability.

(2) *Internal Failure*. Internal failure refers to failures within the soil-nailed ground mass. Internal failures can occur in the active zone, passive zone, or in both of the two zones of a soil-nailed system.

In the active zone, internal failure modes include:

- (a) failure of the ground mass, i.e., the ground disintegrates and ‘flows’ around the soil nails and soil-nail heads,
- (b) bearing failure underneath soil-nail heads,
- (c) structural failure of the soil nail under combined actions of tension, shear and bending,
- (d) structural failure of the soil-nail head or facing, i.e., bending or punching shear failure, or failure at head-reinforcement or facing-reinforcement connection, and
- (e) surface failure between soil-nail heads, i.e., washout, erosion, or local sliding failure.

In the passive zone, pullout failure at ground-grout interface or grout-reinforcement interface should be considered.

5.3.3 Models

The heterogeneity of ground conditions renders the formulation of appropriate design models and design groundwater conditions a difficult task. There should be adequate engineering geological input to the ground investigation and formulation of representative ground and groundwater models for stability assessment and design verification during construction. In general, models are developed with varying degrees of rigour to:

- (a) consider potential variations in ground and groundwater conditions,
- (b) determine site investigation requirements, and
- (c) facilitate the interpretation of the ground and groundwater conditions to provide a basis for design.

In order to ensure the adequacy of engineering geological input, a three-step approach comprising ‘geological’, ‘ground’ and ‘design’ models should be adopted. A geological model is used to characterise a site where the focus is placed on geological, geomorphological and hydrogeological features, and characteristics that are relevant to an engineering project.

A ground model builds on the geological model and integrates the range of engineering parameters and ground conditions that need to be considered in the design. It refines the geological model by defining and characterising bodies of ground with similar engineering properties, and identifies boundaries at which changes in geotechnical conditions may occur. A design model, on the other hand, is concerned primarily with assessment of the response of the ground to the proposed works, and vice versa, for use in geotechnical assessment or engineering design. Design models for empirical, prescriptive and quantitative designs depend on the engineering application, degree of conservatism in the empirical/prescriptive models and the level of geotechnical risk.

Reference should be made to GEO Publication No. 1/2007 : Engineering Geological Practice in Hong Kong (GEO, 2007a) for further guidance on the establishment of appropriate models and engineering geological input. Special care should also be exercised in the evaluation of the design groundwater conditions if the groundwater regime may be affected by changes to environmental conditions, e.g., when a hard slope surface cover is to be replaced by a vegetated cover. The ground and groundwater models should be updated throughout the design and construction stages as new information is revealed.

5.3.4 Methods of Stability Analysis

Different analytical methods are available for assessing the stability of a soil-nailed system. The majority of these are limit equilibrium analyses based on the method of slices. In choosing the method of limit equilibrium analysis, designers should consider whether the method satisfies all the conditions of equilibrium. The calculated factors of safety given by methods that consider force equilibrium or moment equilibrium only may not give correct results. Therefore, only methods that satisfy both force and moment equilibrium should be used for the analysis (Shiu et al, 2007).

Under special circumstances, a stress-strain analysis may be required for assessing the design capacity of soil nails or for ground deformation assessment. For instance, if the soil nails are steeply inclined, the tensile forces that can be mobilised in the soil nails may be much less than those for slightly inclined soil nails. In this case, finite element or finite difference method may be used for the analysis. There are different ways of incorporating the results of such numerical analysis in slope stability assessment, e.g., the strength reduction method, and the approach of coupling numerical analysis with limit equilibrium method adopted by Krahn (2003). Designers should select a method that best suits the specific purpose of the case being considered.

The common calculation methods involving conventional earth pressure theories and consideration of force and moment equilibrium can be used for the stability analysis of soil-nailed retaining walls.

5.4 DESIGN FOR SERVICEABILITY

The performance of a soil-nailed system should satisfy the serviceability requirements in respect of deformation, otherwise it may result in excessive ground settlement, facing deterioration, or damage to a surface or subsurface drainage system. The deformation of a

soil-nailed system is governed by various factors, which include the ground profile, soil stiffness, groundwater conditions, layout of soil nails, slope facing and construction workmanship. The soil nailing technique is commonly applied to enhance the stability of soil cut slopes in Hong Kong. The deformation of such soil-nailed systems is generally small if they are designed and constructed in accordance with this Geoguide, and a deformation analysis is generally not required.

When excessive deformation of a soil-nailed system is a cause for concern, a deformation analysis should be carried out. For example, for those slopes and retaining walls that are reinforced by steeply inclined soil nails, or where the soil nails are required to carry sustained loads, a deformation analysis may be warranted (see [Sections 5.6.3](#) and [5.12.2](#)). The analysis should demonstrate that the anticipated deformations of the soil-nailed system are within acceptable limits with due consideration given to the serviceability requirements of the affected structures, facilities and services. Numerical modelling using stress-strain finite element or finite difference computer programs, or other suitable tools may be used for the analysis. General guidance on the selection of the deformation parameters can be found in Geoguide 1 : Guide to Retaining Wall Design (GEO, 1993).

5.5 DESIGN FOR DURABILITY

Soil-nailed systems should be sufficiently durable, so that they are capable of withstanding attack from the existing and envisaged corrosive environment without unduly affecting their stability and serviceability. Appropriate corrosion protection measures should be provided to the steel reinforcement. Common corrosion protection measures used in Hong Kong can be divided into three classes:

- (a) Class 1 - Hot-dip galvanising with a minimum zinc coating of 610 g/m^2 to BS EN ISO 1461: 1999 (BSI, 1999) plus corrugated plastic sheathing in accordance with the General Specification for Civil Engineering Works (CEDD, 2006a),
- (b) Class 2 - Hot-dip galvanising with a minimum zinc coating of 610 g/m^2 to BS EN ISO 1461: 1999 (BSI, 1999) plus a 2 mm sacrificial thickness on the radius of the steel reinforcement, and
- (c) Class 3 - Hot-dip galvanising with a minimum zinc coating of 610 g/m^2 to BS EN ISO 1461: 1999 (BSI, 1999).

The provision of corrosion protection measures to steel reinforcement should be based on soil aggressivity, as well as the loading condition and design life of the soil nails. Guidance on the classification of soil aggressivity is given in [Section 4.3](#). The recommended corrosion protection measures for soil nails carrying transient loads are given in [Table 5.1](#). Typical details of Class 1 corrosion protection measures are given in [Figure 5.3](#).

More stringent corrosion protection measures are required for soil nails carrying sustained load. The design guidance is given in [Section 5.12.2](#).

Table 5.1 Recommended Corrosion Protection Measures for Soil Nails Carrying Transient Loads

Design Life	Soil Aggressivity Classification			
	Highly aggressive	Aggressive	Mildly aggressive	Non-aggressive
Up to 120 years	Class 1		Class 2	
Up to 2 years ^(Note 2)	Class 3			

Corrosion Protection Measures:

Class 1 - Hot-dip galvanising with a minimum zinc coating of 610 g/m² and corrugated plastic sheathing

Class 2 - Hot-dip galvanising with a minimum zinc coating of 610 g/m² and 2 mm sacrificial thickness on the radius of the steel reinforcement

Class 3 - Hot-dip galvanising with a minimum zinc coating of 610 g/m²

- Notes:
- (1) For “potentially aggressive” sites without soil aggressivity assessment, Class 1 corrosion protection measures should be provided to soil nails with a design life more than 2 years.
 - (2) Soil aggressivity assessment is not required for soil nails with a design life up to 2 years.

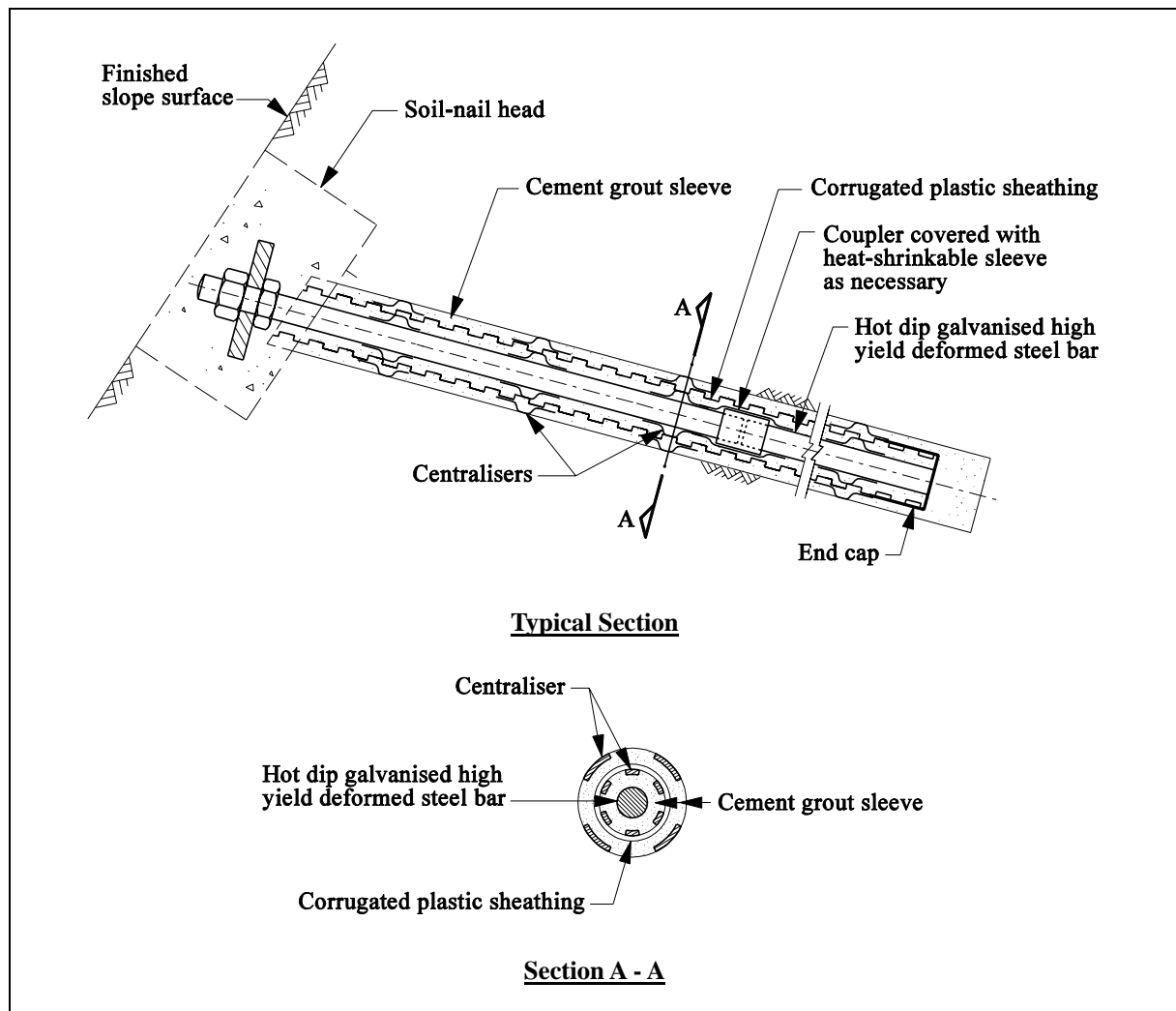

Figure 5.3 Typical Details of Class 1 Corrosion Protection Measures

Other types of corrosion protection measures, which provide comparable or better protection to soil-nail reinforcement to those recommended in [Table 5.1](#), may be used with due consideration of the following factors:

- (a) reliability and long-term performance of the measure,
- (b) effect on bond strength at the grout-reinforcement interface,
- (c) cost,
- (d) availability in the market, and
- (e) ease of handling and quality control on site.

5.6 ANALYTICAL DESIGN OF SOIL NAILS IN SOIL CUT SLOPES

5.6.1 General

Soil nails used to reinforce both new and existing soil cut slopes can be designed analytically. Appropriate ground and groundwater models should be established and design parameters should be obtained through detailed site investigation as discussed in [Section 5.3.3](#). Recommended minimum factors of safety and design procedures for soil-nail reinforcement, soil-nail heads and slope facing are given in [Sections 5.6.2](#) to [5.6.5](#).

The design groundwater conditions and foundation loading should follow the recommendations given in the Geotechnical Manual for Slopes (GCO, 1984). Guidance on surcharge loading should follow those presented in Geoguide 1 : Guide to Retaining Wall Design (GEO, 1993) for retaining wall, which is also applicable to the design of soil-nailed cut slopes.

5.6.2 Factor of Safety

The reliability of a soil-nailed system depends not only on the calculated factor of safety, but also on the method of analysis, uncertainties in the ground and groundwater models, the representativeness of the assumed geotechnical parameters and the quality achieved in construction. It should be noted that factors of safety cannot overcome gross errors and non-compliance with specifications.

The required factor of safety against failure of a soil-nailed cut slope along a potential failure surface depends on the consequence of failure. Two types of consequences should be considered, namely the “consequence-to-life” and “economic consequence”. Examples of slope failures in different categories under these two consequence classifications are given in [Tables 5.2](#) and [5.3](#) respectively. The recommended minimum factors of safety against failure of a soil-nailed cut slope along a potential failure surface should follow those given in the Geotechnical Manual for Slopes (GCO, 1984) for un-reinforced slopes. The relevant standards are shown in [Tables 5.4](#) and [5.5](#).

Table 5.2 Typical Examples of Slope Failures in Each Consequence-to-life Category

Examples	Consequence-to-life		
	Category 1	Category 2	Category 3
(1) Failures affecting occupied buildings (e.g., residential, educational, commercial or industrial buildings, bus shelters, railway platforms).	✓		
(2) Failures affecting buildings storing dangerous goods.	✓		
(3) Failures affecting heavily used open spaces and recreational facilities (e.g., sitting-out areas, playgrounds, car parks).		✓	
(4) Failures affecting roads with high vehicular or pedestrian traffic density.		✓	
(5) Failures affecting public waiting areas (e.g., bus stops, petrol stations).		✓	
(6) Failures affecting country parks and lightly used open-air recreational areas.			✓
(7) Failures affecting roads with low traffic density.			✓
(8) Failures affecting storage compounds (non-dangerous goods).			✓

Table 5.3 Typical Examples of Slope Failures in Each Economic Consequence Category

Examples	Economic Consequence		
	Category A	Category B	Category C
(1) Failures affecting buildings, which could cause excessive structural damage.	✓		
(2) Failures affecting essential services, which could cause loss of that service for an extended period.	✓		
(3) Failures affecting rural or urban trunk roads or roads of strategic importance.	✓		
(4) Failures affecting essential services, which could cause loss of that service for a short period.		✓	
(5) Failures affecting rural (A) or primary distributor roads which are not sole accesses.		✓	
(6) Failures affecting open-air car parks.			✓
(7) Failures affecting rural (B), feeder, district distributor and local distributor roads which are not sole accesses.			✓
(8) Failures affecting country parks.			✓

Table 5.4 Recommended Minimum Factor of Safety against Failure for New Soil-nailed Cut Slopes for a Ten-year Return Period Rainfall

Economic Consequence \ Consequence-to-life	Category 1	Category 2	Category 3
Category A	1.4	1.4	1.4
Category B	1.4	1.2	1.2
Category C	1.4	1.2	> 1.0

Notes: (1) In addition to a minimum factor of safety of 1.4 for a ten-year return period rainfall, a slope in the consequence-to-life category 1 should have a factor of safety of at least 1.1 for the predicted worst groundwater conditions.
 (2) The factors of safety given in this Table are recommended minimum values. Higher factors of safety might be warranted in particular situations in respect of loss of life and economic loss.

Table 5.5 Recommended Minimum Factor of Safety against Failure for Existing Cut Slopes Upgraded by Soil Nails for a Ten-year Return Period Rainfall

Consequence-to-life	Category 1	Category 2	Category 3
Minimum Factor of Safety	1.2	1.1	> 1.0

Notes: (1) These factors of safety are appropriate only where rigorous geological and geotechnical studies have been carried out (which should include a thorough examination of maintenance history, groundwater records, rainfall records and any monitoring records), where the slope has been standing for a considerable time, and where the loading conditions, the groundwater regime, and the basic form of the modified slope remain substantially the same as those of the existing slope. Otherwise, the standards specified for new slopes given in [Table 5.4](#) should be adopted.
 (2) The factors of safety given in this Table are recommended minimum values. Higher factors of safety might be warranted in particular situations in respect of loss of life and economic loss.

The recommended minimum factors of safety against the three modes of internal failure of a soil nail, viz., (i) tensile failure of soil-nail reinforcement, (ii) pullout failure at soil-grout interface, and (iii) pullout failure at grout-reinforcement interface are given in [Table 5.6](#). This is independent of the failure consequence of the slope.

Table 5.6 Recommended Minimum Factor of Safety against Internal Failure of a Soil Nail

Mode of Internal Failure	Minimum Factor of Safety
Tensile failure of soil-nail reinforcement	$F_T = 1.5$
Pullout failure at soil-grout interface	$F_{SG} = 1.5$ ^(Note 1) $F_{SG} = 2.0$ ^(Note 2)
Pullout failure at grout-reinforcement interface	$F_{GR} = 2.0$

Notes: (1) For soil nails carrying transient loads and bonded in weathered granite or volcanic rocks.
 (2) For soil nails carrying sustained loads or for soil nails carrying transient loads and bonded in soils other than weathered granite or volcanic rocks.

5.6.3 Soil-nail Reinforcement

(1) *General.* The size, length, spacing and inclination of soil nails should be designed to provide the required stabilising force to the reinforced soil mass.

(2) *Soil-nail Capacity.* The capacity of a drill-and-grout soil nail is governed by the tensile capacity of the soil-nail reinforcement, the size of the soil nail, i.e., perimeter and length, the bond stress that can be mobilised at the soil-grout interface and at the grout-reinforcement interface, and the resistance that can be provided by the soil-nail head or facing. The bond strength between the soil-nail reinforcement and the cement grout depends on the mechanical interlocking between the cement grout, and the protrusions and depressions in the surface of the soil-nail reinforcement. This in turn is affected by the combined effect of adhesion, friction and bearing. If high yield deformed steel bars with transverse ribs are used as soil-nail reinforcement, the bearing stress between the ribs and cement grout contributes most of the bond. The bond strength between cement grout and the soil depends primarily on the contact stress and the interface coefficient of friction between the cement grout and the soil.

The allowable tensile capacity, T_T , of a soil nail is given by:

$$T_T = \frac{f_y A'}{F_T} \dots\dots\dots(5.1)$$

where f_y = characteristic yield strength of the soil-nail reinforcement
 A' = effective cross-sectional area of the soil-nail reinforcement
 F_T = factor of safety against tensile failure of soil-nail reinforcement

In general, there is no need to check the degree of reduction in soil-nail capacity due to the combined actions of tension, shear and bending. It is because for slightly inclined soil nails, the reduction in soil-nail capacity due to such combined actions is insignificant. In addition, due to the ductile behaviour of steel reinforcement and the high redundancy of a soil-nailed cut slope, upon yielding of a soil nail, the extra load can be redistributed to other soil nails. However, if the soil nails are steeply inclined, the effectiveness of the soil nails in mobilising tensile forces will be reduced significantly. In such cases, the soil-nail capacity of the soil nails should be assessed under the combined actions of tension, shear and bending (see also [Section 5.6.3\(6\)](#)).

The allowable pullout resistance provided by the soil-grout bond length in the passive zone, T_{SG} , can be determined using the effective stress method:

$$T_{SG} = \frac{c' P_c L + 2D\sigma'_v \mu^* L}{F_{SG}} \dots\dots\dots(5.2)$$

where c' = effective cohesion of the soil
 P_c = outer perimeter of the cement grout sleeve
 L = bond length of the soil-nail reinforcement in the passive zone
 D = outer diameter of the cement grout sleeve

- σ'_v = vertical effective stress in the soil calculated at mid-depth of the soil-nail reinforcement in the passive zone, with a maximum value of 300 kPa
- μ^* = coefficient of apparent friction of soil (μ^* may be taken to be equal to $\tan \phi'$, where ϕ' is the angle of shearing resistance of the soil under effective stress condition)
- F_{SG} = factor of safety against pullout failure at soil-grout interface

It should be noted that like other methods, the effective stress method has limitations and the pullout resistance of a drill-and-grout soil nail assessed by this method is only an estimate based on simplified assumptions. The effective stress method does not account for factors including soil arching, restrained soil dilatancy, soil suction, roughness of drillhole surface, over-break, etc. Nevertheless, experience has shown that use of the method together with the recommended factor of safety, F_{SG} , gives an adequately safe design solution for the ground and groundwater conditions commonly encountered in Hong Kong. As a precaution against the possibility that the positive contribution to the pullout resistance from soil dilatancy, drillhole irregularities, etc., being less than the negative effect due to soil arching in the case of high overburden pressure, it is recommended to limit the maximum overburden pressure to 300 kPa in the estimation of pullout resistance using the effective stress method.

There are other methods of estimation of the pullout resistance of soil nails, such as empirical correlation with SPT-N values or pressuremeter test results, and verification by site-specific pullout tests. The merits and limitations of these methods are described by Pun & Shiu (2007). Designers may consider using these methods to establish site-specific empirical correlation or design parameters with due consideration given to the adequacy and quality of the field data, representativeness of the test results, the reliability of any empirical correlation and the safety margin needed.

The allowable pullout resistance provided by the rock-grout bond length in the passive zone depends on the strength, degree of jointing and fissuring, and the inclination of discontinuities in the rock mass. In the absence of detailed investigation, a presumed value of rock-grout bond strength of 0.35 MPa may be used for determining the pullout capacity if the soil nail is socketed into a partially weathered rock mass of PW90/100 or better rock zone. A higher value of design bond strength may be assumed if this can be justified by the designer through detailed ground investigation, testing and analysis. A minimum rock socket length of 2 m is recommended to cater for the variation in strength and properties of the rock mass in the transition zone along the soil-rock interface.

The allowable pullout resistance provided by the grout-reinforcement bond length in the passive zone, T_{GR} , is given by:

$$T_{GR} = \frac{\beta \sqrt{f_{cu}} P_r L}{F_{GR}} \dots\dots\dots(5.3)$$

- where β = coefficient of friction at the grout-reinforcement interface, which depends on the bar type characteristic in accordance with BS 8110 (BSI, 1997), e.g., 0.5 for high yield deformed steel bars
- f_{cu} = characteristic strength of cement grout
- P_r = effective perimeter of the soil-nail reinforcement

L = bond length of the soil-nail reinforcement in the passive zone
 F_{GR} = factor of safety against pullout failure at grout-reinforcement interface

(3) *Diameter.* High yield deformed steel bars of diameter 25 mm, 32 mm and 40 mm are commonly used in Hong Kong as soil-nail reinforcement. Bars having small diameters should be used with caution, particularly in the case of long soil nails, because they tend to bend excessively during installation.

(4) *Length.* Long soil nails, typically over 20 m, should be used with caution. Due consideration should be given to the buildability of the soil nails (see [Section 4.2](#)) to ensure that the design is buildable and the quality of the soil nails would not be unduly affected.

Long soil nails also require larger movement than short soil nails in mobilising the full capacity of the soil nails. This may result in substantial ground deformation, especially where the ground comprises loose material or the ground mass around the soil nails is weakened by disturbance associated with drilling difficulties.

(5) *Spacing.* Widely-spaced soil nails may not be effective in ensuring that the soil nails and the ground act as an integral mass, and in preventing local instability between soil nails. Conversely, soil nails that are too close may not be cost-effective and may be difficult to install properly. In Hong Kong, soil nails are commonly installed at a spacing of 1.5 m to 2.0 m. Horizontal rows of soil nails should be staggered to improve the integral action between the soil nails and the ground.

Some methods are available to enhance the nail-ground interaction and local stability between soil nails. For example, the nail-ground interaction can be enhanced by provision of proper soil-nail head and facing, and the local stability between soil nails can be improved by installation of intermediate short-length soil nails between working soil nails.

(6) *Inclination.* Theoretically the effectiveness of the soil nails will be maximised if they are installed at their corresponding optimum soil-nail orientations, i.e., aligned with the direction of the maximum tensile strain of the soil. This will lead to different soil-nail inclination, which is the angle of a soil nail to the horizontal. However, for practical reasons, soil nails are commonly installed at a uniform inclination.

Soil nails are usually inclined downwards, typically 5° to 20°, to facilitate proper grouting, which is carried out under gravity or low pressure. A small downward inclination can also maximise the average tensile reinforcing effect of the soil nails in the reinforced soil mass. The average reinforcing effect of soil nails will, however, decrease significantly with increasing soil-nail inclination. Where it is necessary to steepen the soil-nail inclination to accommodate physical constraints, consideration should be given to the effectiveness of the soil nails and the amount of slope deformation required to mobilise the design soil-nail forces. Stress-strain analysis by finite element or finite difference method (see [Section 5.3.4](#)) may be used to study the behaviour of the soil nails and their effectiveness under combined actions of tension, shear and bending. Reference should be made to [Section 3.4](#) on the effect of soil-nail inclination in the mechanism of nail-ground interaction.

5.6.4 Soil-nail Head

Soil-nail heads should be designed to provide an adequate safety margin against bearing capacity failure of the soil underneath the soil-nail heads and structural failure of the heads. The recommended sizes of isolated soil-nail heads for cut slopes with an angle steeper than 45° are given in Table 5.7. Alternatively, the sizes of soil-nail heads can be designed using the method recommended by the UK Department of Transport (DOT, 1994) as shown in Figure 5.4.

The typical reinforcement details of an isolated soil-nail head are shown in Figure 5.5. Alternatively, the structural design of soil-nail heads and their connection with reinforcement should follow the recommendations stipulated in relevant structural design codes. The soil pressure acting beneath the soil-nail head may be assumed to be uniform.

Table 5.7 Recommended Sizes of Isolated Soil-nail Heads

Soil Shear Strength Parameter near the Slope Surface		$45^\circ \leq \text{Slope Angle} < 55^\circ$			$55^\circ \leq \text{Slope Angle} < 65^\circ$			Slope Angle $\geq 65^\circ$		
		Diameter of Soil-nail Reinforcement (mm)			Diameter of Soil-nail Reinforcement (mm)			Diameter of Soil-nail Reinforcement (mm)		
ϕ'	c' (kPa)	25	32	40	25	32	40	25	32	40
34°	2	800	800	800	600	600	800	600	600	800
	4	600	800	800	600	600	800	600	600	800
	6	600	800	800	400	600	800	400	600	600
	8	600	600	800	400	600	800	400	600	600
	10	400	600	800	400	600	600	400	600	600
36°	2	600	800	800	600	600	800	600	600	800
	4	600	800	800	400	600	800	400	600	800
	6	600	600	800	400	600	800	400	600	600
	8	400	600	800	400	600	600	400	600	600
	10	400	600	800	400	600	600	400	400	600
38°	2	600	800	800	400	600	800	600	600	600
	4	600	600	800	400	600	800	400	600	600
	6	400	600	800	400	600	600	400	600	600
	8	400	600	800	400	600	600	400	400	600
	10	400	600	800	400	400	600	400	400	600
40°	2	600	600	800	400	600	800	600	600	600
	4	400	600	800	400	600	600	400	400	600
	6	400	600	800	400	600	600	400	400	600
	8	400	600	600	400	400	600	400	400	600
	10	400	600	600	400	400	600	400	400	600

- Notes:
- (1) Dimensions are in millimetres unless stated otherwise.
 - (2) Only the width of the square soil-nail head is shown in the Table.
 - (3) The minimum thickness of the soil-nail head should be 250 mm.
 - (4) This table is based on the findings of the study in GEO Report No. 175 (Shiu & Chang, 2005).

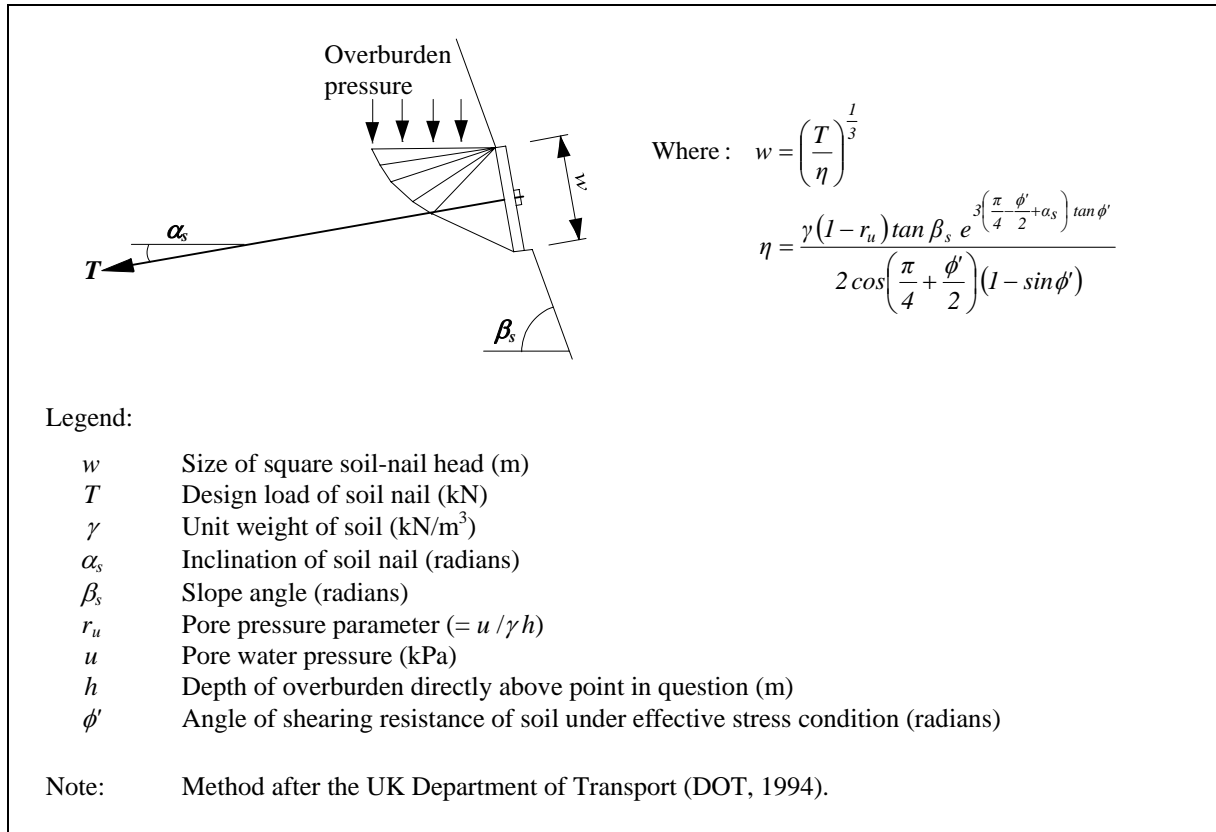

Figure 5.4 Soil-nail Head Design Method Recommended by the UK Department of Transport

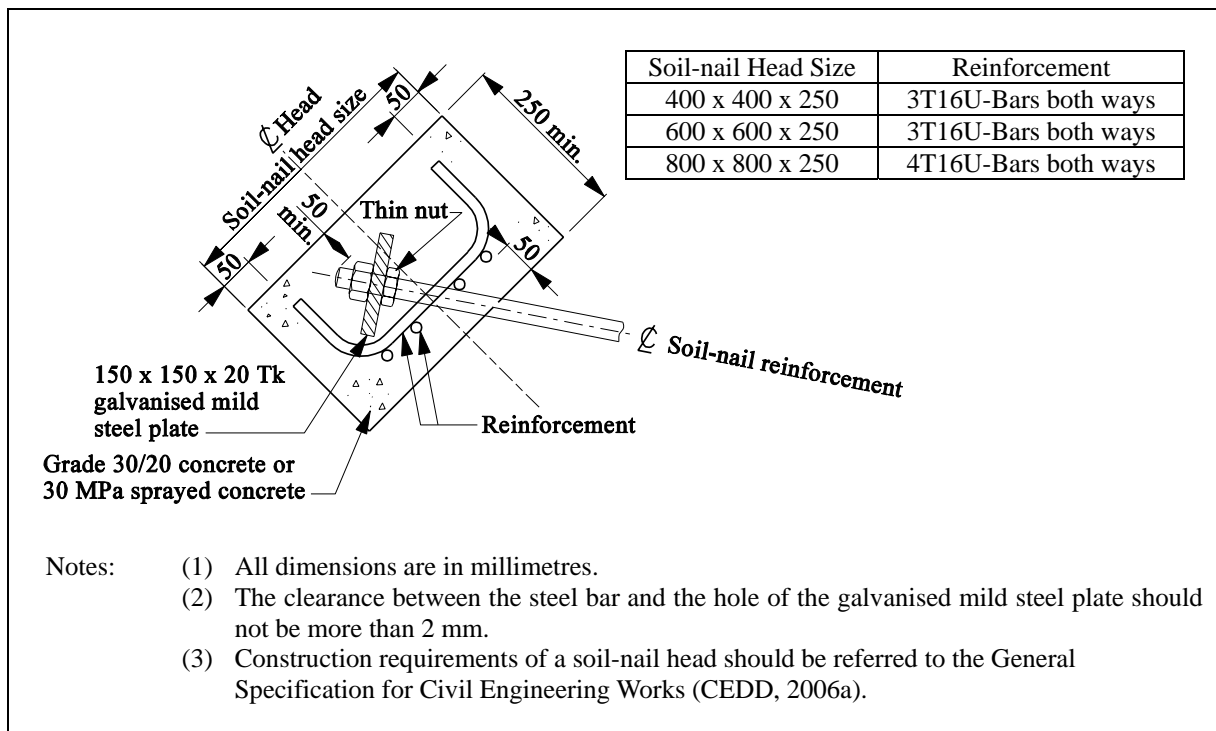

Figure 5.5 Typical Reinforcement Details of a Soil-nail Head

The effectiveness of the soil-nail heads in mobilising tensile forces of soil nails may decrease as the slope angle decreases (see [Section 3.4](#)). Designers should give due consideration to ensure effective interaction between the soil-nail heads and the ground for gentle slopes, such as in the case of natural hillsides. The typical details as shown in [Figure 5.6](#) may be adopted for a gentle slope to enhance the effectiveness of the head. The size of the soil-nail head can be determined based on [Figure 5.4](#).

Apart from mobilisation of tensile forces, a side benefit of soil-nail heads is to enhance local stability between soil nails. Further guidance on prevention of local instability by slope facing is given in [Section 5.6.5](#).

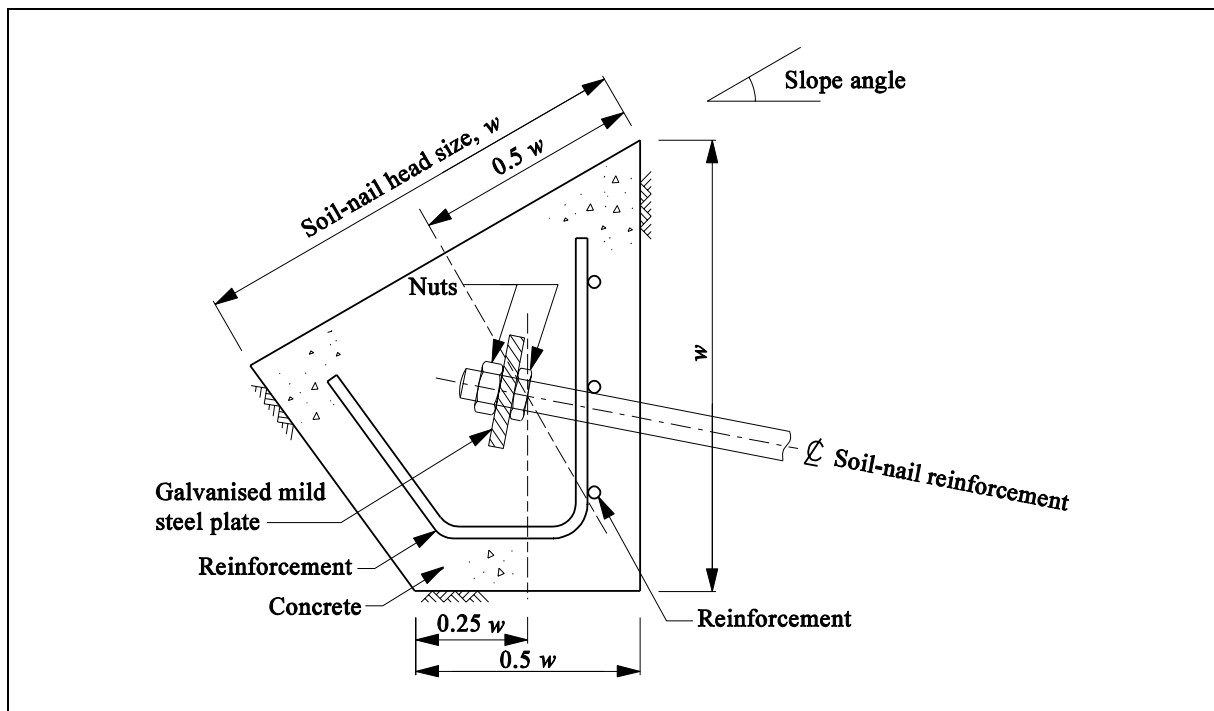

Figure 5.6 Typical Details of a Soil-nail Head for a Gentle Slope

5.6.5 Slope Facing

A slope facing primarily serves to provide the slope with surface protection, and to minimise erosion and other adverse effects of surface water on the slope. It may be soft, flexible, hard, or a combination of the three. A soft slope facing is non-structural, whereas a flexible or hard slope facing can be either structural or non-structural. Flexible structural facings can provide stability to the face of a soil-nailed system by distributing the loads among soil-nail heads. These facings allow a certain degree of ground deformation. The function of hard structural facings is similar to that of flexible structural facings but with less ground deformation allowance. Both flexible and hard structural facings provide structural connectivity between soil nails, which promotes integral action of the soil-nailed cut slope and enhances local stability of the slope surface.

Failure cases on vegetated soil-nailed slopes involving local and minor erosion or

detachment from shallow depths in the near-surface within the active zone of the soil-nailed system have been reported in Hong Kong. Reference may be made to Ng et al (2008) on the details of the failure cases. Many of these slopes previously had a hard surface cover, which was replaced by vegetation when soil nails were installed. Designers should provide suitable slope facings with due consideration given to the stability and cost benefit of the options. For slope facing requiring long-term maintenance, designers should take into account the maintenance requirements throughout the design life of the soil-nailed cut slope. Consideration should be given to the following factors in the choice of slope facing:

- (a) effectiveness in providing surface protection and erosion control,
- (b) effectiveness in redistributing soil-nail forces between soil nails as deformation of the slope takes place,
- (c) effectiveness in preventing local failure between soil-nail heads,
- (d) ease of construction,
- (e) time for vegetation establishment,
- (f) maintenance requirements,
- (g) initial and maintenance cost, and
- (h) aesthetics.

The use of a non-degradable erosion control mat in conjunction with a steel wire mesh enhances local stability effectively and controls surface erosion of soils between soil-nail heads. In order to ensure a good contact between the erosion control mat and the slope surface, it is recommended that the steel wire mesh is stretched slightly and anchored onto the concrete soil-nail heads. This can also cater for possible local detachments and reduce the consequences of failure. For sensitive structures with high risk and failure consequence, enhanced surface protection systems such as an actively stressed steel wire mesh and grillage system can be adopted.

As an alternative to isolated reinforced concrete soil-nail heads, a grillage system can provide better resistance to local surface failures and promote integral action of the reinforced soil mass. The structural support should be designed to take account of the induced bending, shear and punching forces in its design life. For heavy structural support on steep ground, significant downward and outward movements of the support may occur due to its weight. This should be taken into account in the design to avoid excessive ground deformation. Suitable landscape treatment should be provided to mitigate any potential visual impact of the structural support. Reference can be made to [Section 5.11](#).

Where the slope surface is irregular, consideration should be given to suitable local trimming, as necessary, prior to soil nail construction. A smooth and less steep slope profile can also facilitate more effective construction of the slope facing. In the case of a steep cut

slope where there is a concern about local instability, sufficient confinement on the slope surface should be provided to prevent excessive deformation and disintegration of the soil mass at shallow depths so that the full capacity of soil nails can be utilised.

For the design of non-structural facings, consideration should be given to their sustainability and ability to resist the loads imparted by the soil-nail heads to avoid failure by puncturing or rupture and/or excessive bulging under working conditions. For structural facings, design considerations should include:

- (a) punching shear resistance,
- (b) flexural resistance,
- (c) structural capacity of connections, and
- (d) durability.

Reference may be made to GEO Publication No. 1/2000 : Technical Guidelines on Landscape Treatment and Bio-engineering for Man-made Slopes and Retaining Walls (GEO, 2000b) and GEO Technical Guidance Note No. 20 (GEO, 2007b) for guidance on different greening techniques suitable for forming soft facing, and CIRIA (2005) for the design guidance on flexible and hard structural facings. Recommendations on prescriptive design of soft facing based on slope gradient are given in GEO Report No. 56 (Wong et al, 1999). Specifications for surface protection materials can be found in the General Specification for Civil Engineering Works (CEDD, 2006a).

5.7 ANALYTICAL DESIGN OF SOIL NAILS IN RETAINING WALLS

5.7.1 General

The analytical design of soil nails in retaining walls should follow the guidance given in this Section. Appropriate ground and groundwater models should be established and design parameters should be obtained through detailed site investigation as discussed in [Section 5.3.3](#). The guidance on the design of soil nails in upgrading existing retaining walls is given in [Sections 5.7.2](#) to [5.7.4](#).

Soil nails may be used in conjunction with new retaining walls, although such design options have seldom been used in Hong Kong. The guidance given in [Sections 5.7.3](#) and [5.7.4](#) is generally applicable to the use of soil nails in new retaining walls. The design approach, factor of safety and calculation methods for verification of safety and serviceability should follow the guidance given in Geoguide 1 : Guide to Retaining Wall Design (GEO, 1993). The soil-nail capacity should be determined in accordance with the guidance given in [Section 5.6.3](#) and the recommended factor of safety in [Table 5.6](#). The soil-nail forces should be modelled as external forces. The external stability of the soil-nailed retaining wall can then be assessed using the limit state approach with partial safety factors as given in Geoguide 1.

The stress field and deformation in the ground behind a retaining wall depend on the

mode of failure of the wall. In consideration of the mobilisation of the tensile forces of soil nails, designers should examine the orientation of the soil nails with respect to the potential failure surface of the soil mass and the direction of wall movement in the specific mode of failure being considered. For instance, in the mode of bearing failure, the potential failure surface of the soil mass may be inclined at a steep angle from the horizontal and the wall may have a tendency to move downwards. Under these conditions, the effectiveness of the soil nails may be low.

5.7.2 Factor of Safety

In upgrading existing retaining walls, the soil nails should be designed to provide adequate safety margins against sliding, overturning, bearing and overall instability modes of failure of the walls. The global factor of safety approach is recommended. The safety margin is determined by calculating the factor of safety, F_s , against various modes of failure, which is defined in general terms as:

$$F_s = \frac{\text{Moments or forces aiding stability}}{\text{Moments or forces causing instability}} \dots\dots\dots(5.4)$$

The recommended minimum factors of safety against various modes of failure and the design groundwater conditions should follow those given in the Geotechnical Manual for Slopes (GCO, 1984), which are reproduced in [Table 5.8](#).

Table 5.8 Recommended Minimum Factor of Safety against External Failure for Existing Retaining Walls Upgraded by Soil Nails for a Ten-year Return Period Rainfall

Mode of Failure	Minimum Factor of Safety ^(Note 1)	
	Set 1	Set 2
Sliding	1.5	1.25
Overturning	2.0	1.5
	For a masonry wall, the resultant force acting on the wall base should lie within the middle-third of the base	
Bearing Capacity	3.0	Existing value to be maintained if below 3.0. For a wall with a toe slope, overall stability of the slope must be adequate
Overall Stability	Refer to Table 5.4	Refer to Table 5.5

- Notes:
- (1) The factors of safety in Set 2 are appropriate only where rigorous structural, geological and geotechnical studies have been carried out (which should include a thorough examination of maintenance history, groundwater records, rainfall records and any monitoring records), where the wall has been standing for a considerable time, and where the loading conditions, the groundwater regime, and the basic form of the modified wall remain substantially the same as those of the existing wall. Otherwise, the factors of safety specified in Set 1 should be adopted.
 - (2) The factors of safety given in this Table are recommended minimum values. Higher factors of safety might be warranted in particular situations in respect of loss of life and economic loss.

A calculation model for checking against sliding, overturning and bearing capacity failures of retaining walls with soil nails is given in [Figure 5.7](#). Soil-nail forces are modelled as external loads. The overall stability of retaining walls should be checked by slope stability analysis methods in accordance with the guidance given in [Section 5.3.4](#).

5.7.3 Soil-nail Reinforcement

The guidance given in [Section 5.6.3\(2\)](#) on the determination of the allowable tensile capacity and pullout resistance of soil nails is applicable to the design of soil nails in upgrading existing retaining walls. Considerations on diameter, length, spacing and inclination of soil nails given in [Sections 5.6.3\(3\)](#) to [5.6.3\(6\)](#) are also applicable.

As the quality of fill materials behind existing retaining walls is uncertain (e.g., the material may not be properly compacted), soil nails should be designed to bond into a competent stratum of insitu soil and/or rock mass to ensure that the required pullout resistance can be achieved. In designing the required bond length, only the portion of soil nail that is outside the active zone of the soil-nailed soil mass and within the insitu competent stratum should be considered. A competent stratum is one that will not collapse when saturated and could provide reliable pullout resistance for soil nails. Examples of a competent stratum are saprolite and dense colluvium. Permanent casing should be used in the rubble zone behind the retaining wall to prevent hole collapse, leakage of grout and blockage of a drainage layer. Any cased portion of the soil nails should be ignored in the estimation of pullout resistance.

5.7.4 Soil-nail Head and Facing

Soil-nail heads and facing should be designed to provide an adequate safety margin against structural failure. In selecting the types of soil-nail heads and facing, the following factors should be considered:

- (a) type of the wall,
- (b) slenderness ratio of the wall,
- (c) condition of the wall,
- (d) availability of space in front of the wall, and
- (e) aesthetics.

In upgrading an existing concrete retaining wall, exposed isolated soil-nail heads or tie beams are commonly used, with typical details shown in [Figures 5.8](#) and [5.9](#) respectively. The sizes of soil-nail heads and tie beams should be designed with due consideration given to the bending and shear resistance of the soil-nail heads and the tie beams, as well as the structural integrity of the existing retaining wall. The final appearance of the wall and the available space in front of the wall should also be taken into account in the design. For example, if the existing retaining wall is overlooking a footpath, the lowest row of soil nails should be placed high enough to avoid the exposed soil-nail heads from affecting pedestrians.

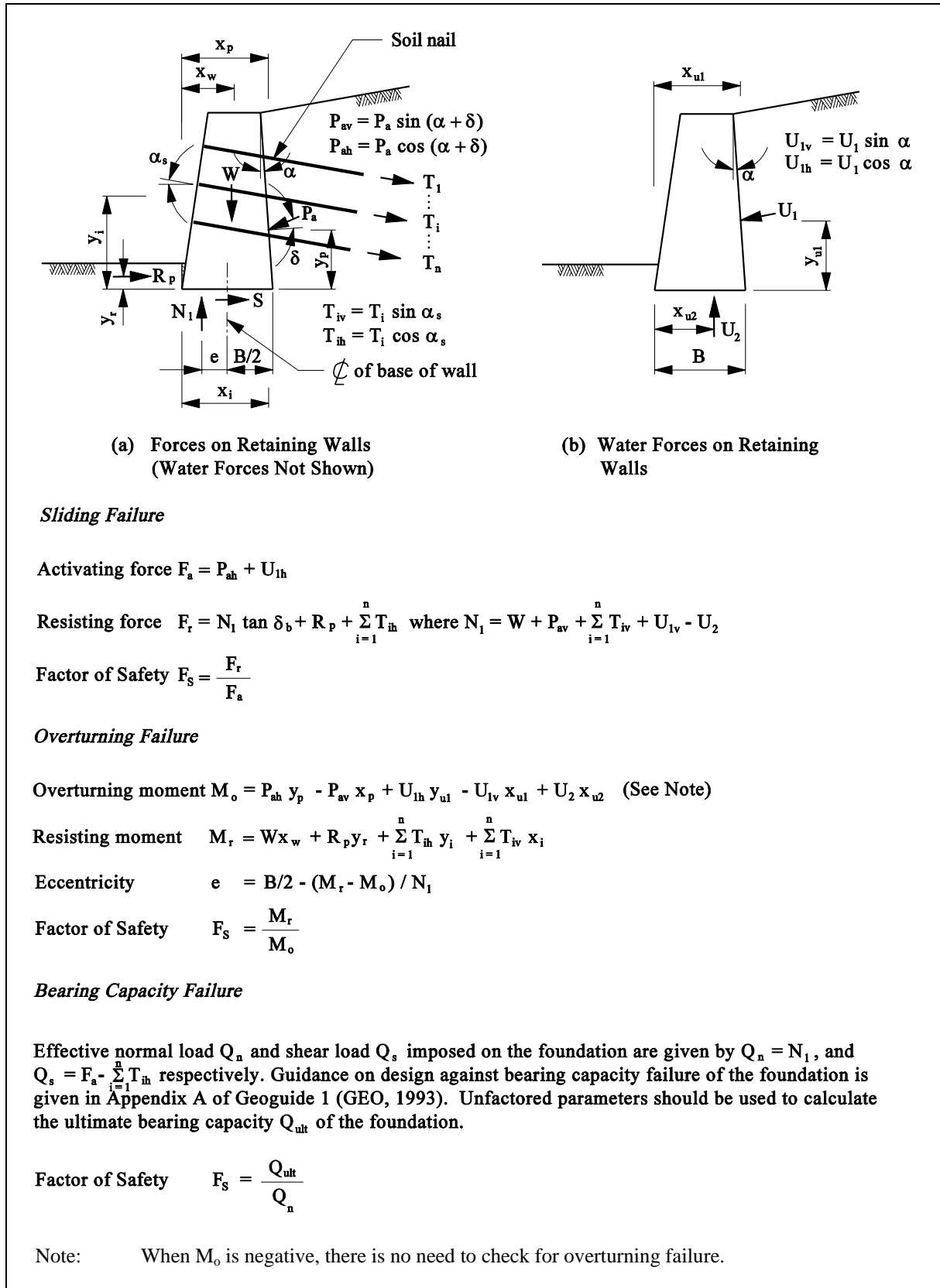

Figure 5.7 Calculation Models for Checking against Sliding, Overturning and Bearing Capacity Failure of a Soil-nailed Retaining Wall

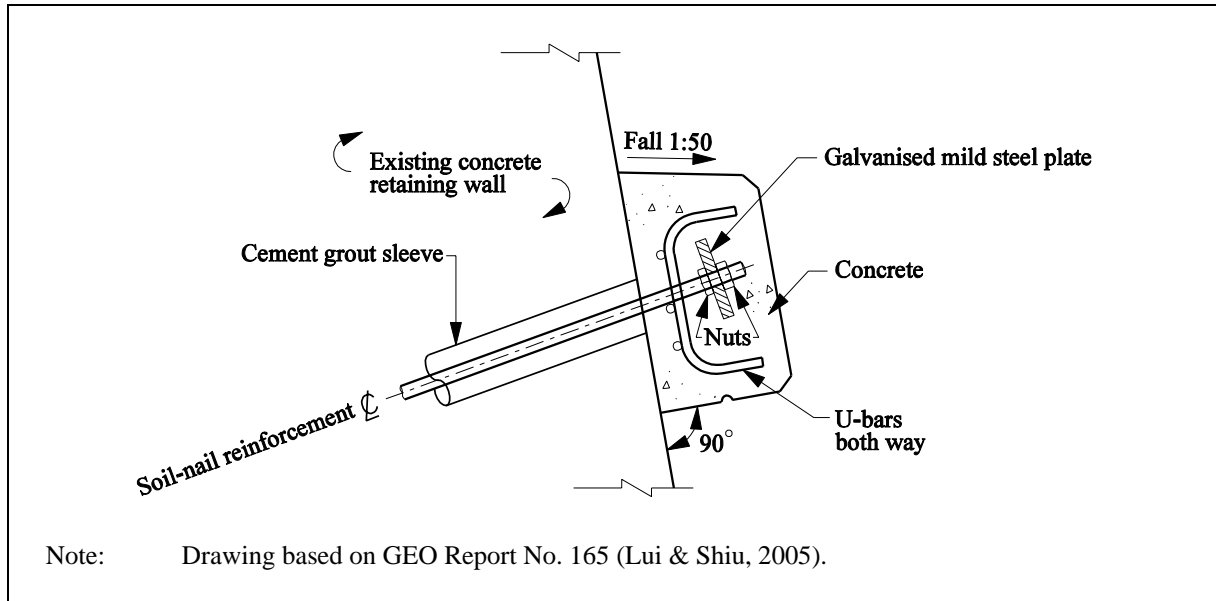

Figure 5.8 Typical Details of an Exposed Isolated Soil-nail Head for a Concrete Retaining Wall

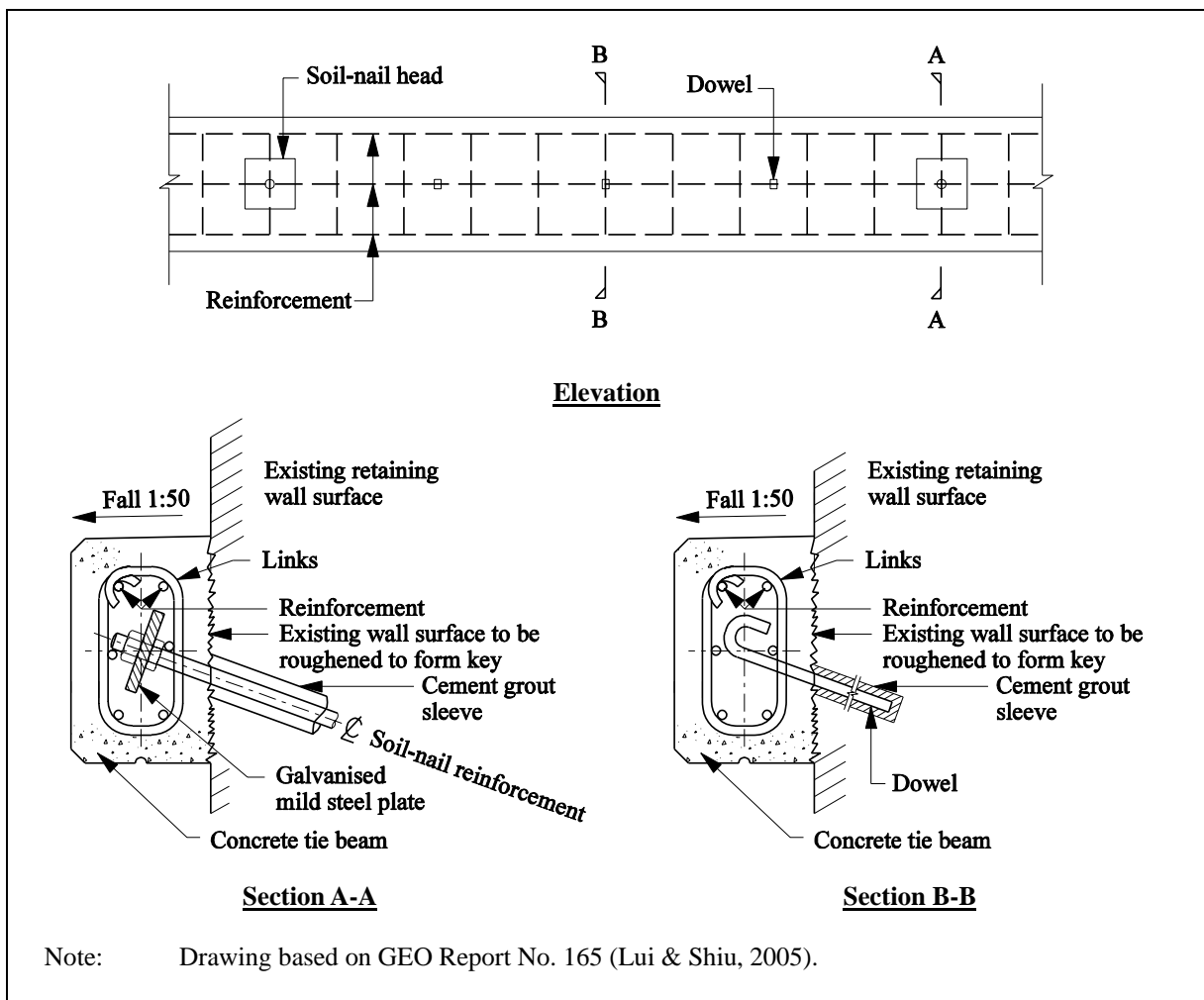

Figure 5.9 Typical Details of an Exposed Tie Beam

If a masonry retaining wall composed of loose blocks is involved, its structural integrity should be considered in the design. In order to promote the integral action of the soil-nailed masonry retaining wall, a concrete skin wall, in lieu of isolated soil-nail heads, should be used to spread the concentrated soil-nail force. The skin wall should be embedded adequately into the ground to enhance the overall stability of the retaining wall. As an alternative to a skin wall, a grillage of concrete beams can be used if the wall fabric has to be preserved. Furthermore, dowel bars should be embedded fully into the body of the masonry wall to ensure that an adequate anchorage can be developed. Typical connection details of a skin wall with soil nails are shown in [Figure 5.10](#).

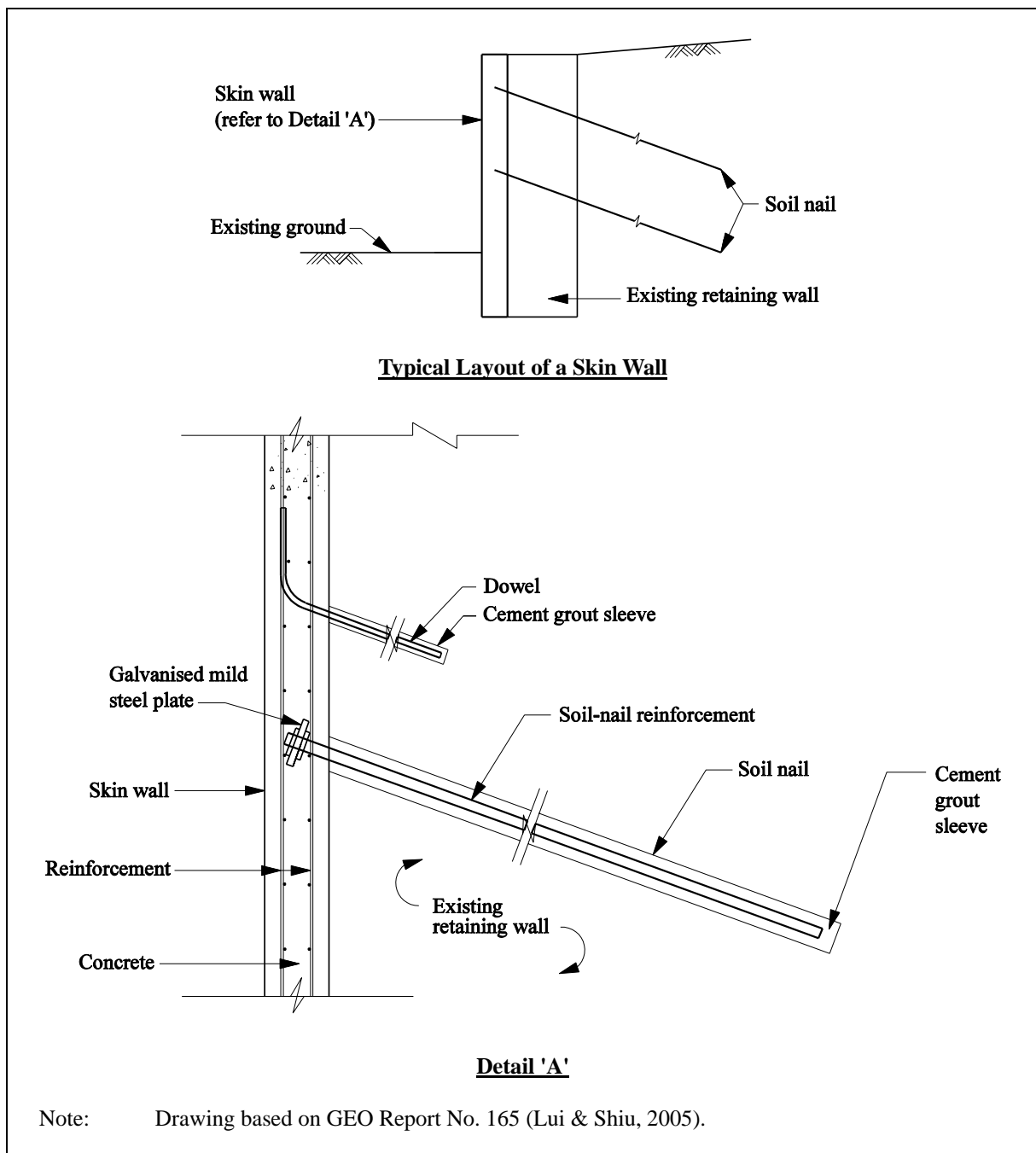

Figure 5.10 Typical Connection Details of a Skin Wall

5.8 ANALYTICAL DESIGN OF SOIL NAILS IN FILL SLOPES

5.8.1 General

If the fill material in a fill slope or embankment exhibits contractive behaviour upon shearing or possesses a structure that might lead to “strain softening”, the fill is classified as loose fill. Where a fill slope is properly compacted and the fill material exhibits dilative behaviour upon shearing, the fill is classified as dense fill. A fill slope formed by end-tipping without compaction should be regarded as loose in the context of this Geoguide.

The design of soil nails, including the soil-nail heads and slope facing, in dense fill slopes is similar to that for soil-nailed cut slope. The design should follow the guidance given in [Section 5.6](#).

Soil nailing is also a feasible option for upgrading loose fill slopes provided that the following qualifying criteria are met:

- (a) the relative degree of compaction of the fill slope is not less than 75%,
- (b) there is no significant sign of distress, history of movement, heavy seepage, nor weak zone (e.g., silt or clay layer) in the slope, and
- (c) the fill slope is not located in an old valley where the groundwater level may be high due to subsurface water flow or leakage from water-carrying services.

For loose fill slopes that do not satisfy the above qualifying criteria, design options other than soil nailing (e.g., re-compaction) should be adopted.

The use of soil nails in loose fill slopes should in-principle follow the recommendations given in the Study Report on Soil Nails in Loose Fill prepared by the Hong Kong Institution of Engineers (HKIE, 2003). The salient points of the recommendations and the supplementary guidelines are given in [Sections 5.8.2](#) to [5.8.4](#).

5.8.2 Factor of Safety

For assessing the stability of soil-nailed loose fill slopes, three scenarios of potential failure should be considered:

- (a) the potential failure of the loose fill materials assuming that the minimum steady state undrained shear strength is mobilised,
- (b) the potential failure of the loose fill materials under drained condition, and

(c) the potential failure of the ground below the fill.

For design scenario (a), a minimum factor of safety of 1.1 should be achieved for any potential failure surface. For internal failure modes of the soil nail, the minimum factors of safety recommended in Section 5.6.2 should be followed, except that the factor of safety against tensile failure of soil-nail reinforcement should follow the value recommended in the Study Report (HKIE, 2003). For design scenarios (b) and (c), the minimum factors of safety as recommended in Tables 5.4 to 5.6 in Section 5.6.2 should be achieved.

5.8.3 Design against Liquefaction

(1) *Design Shear Strength for Loose Fill.* In order to address the concern that when loose fills are subjected to shearing, they may lose strength at such a rate that the forces mobilised in the soil nails will not be able to compensate for the loss of shear strength of the fill, large strain steady state undrained shear strength, c_{ss} , should be adopted for loose fill in the design. If site-specific laboratory testing is not carried out, a conservative value of steady state undrained shear strength equal to 0.2 times the mean effective stress, p'_{peak} , can be adopted, where p'_{peak} is the point at which the fill behaviour changes from drained to undrained in a possible failure scenario. However, the use of the c_{ss}/p'_{peak} correlation to determine the shear resistance at the base of the grillage is not considered appropriate in view of the low stress level. The lower bound values of the shear resistance at the base of the grillage are likely to be within the range of 3 kPa to 10 kPa. If laboratory testing is to be carried out to derive the steady state undrained shear strength of the fill, the testing procedures and guidance given in the Study Report (HKIE, 2003) should be followed.

The general guidance given in Sections 5.2 and 5.3 of Geoguide 1 (GEO, 1993) on the determination of selected values of geotechnical parameters for design is relevant. It is recommended that the selected values of steady state shear strength be obtained from a careful evaluation of the test results. Account should be taken of the adequacy and consistency of the test data, the appropriateness of the test conditions in relation to the likely field conditions and the variability of the fill. The representativeness of the test specimens with respect to the fill mass in the slope that may be susceptible to liquefaction failure (in particular, the range of dry densities and relative compaction values of the fill and the stress levels) should also be considered. Reasonably conservative selected values of shear strength should be adopted. In this respect, sensitivity checks of design parameters should be carried out.

(2) *Design of Nail-grillage System.* Overall stability of the slope should be provided for by the nail-grillage system with the soil nails bonded into a competent subsurface stratum, having spacing not more than 2 m horizontally and 1.5 m vertically. Any contribution of anchorage resistance in the fill should be ignored, i.e., the segment of soil nail in loose fill is considered as free length.

Local stability near the slope surface is provided for by the nail-grillage system. The width of the grillage beams should be designed to provide adequate coverage of the slope surface to prevent the squeezing out of fill material through the opening. The grillage should be designed to withstand the bending moments and shear forces generated by the fill it retains.

Soil nails should be designed to resist the forces acting on the grillage, including the

normal and shear forces generated by the fill. The grillage should be adequately founded on a competent stratum, otherwise a row of vertical supports should be provided along the toe of the grillage to support the system, to absorb any unbalanced forces arising from the possible deviation in alignment of the as-constructed soil nails and to enhance the global stability of the nail-grillage system.

Where steeply inclined soil nails are used, say for resisting the resultant load for the design scenario that the fill has reached the large-strain steady state, the effectiveness of mobilisation of the design soil-nail forces in countering slope failure should also be checked in accordance with the guidance given in [Section 5.6.3\(6\)](#).

Where it warrants, e.g., dense vegetation precludes the use of regularly patterned soil nails, a slab with tree rings instead of a grillage could be used. It is anticipated that there could be considerable construction difficulties experienced on site in the installation of soil nails in fill. These may include ground movement resulting from ground loss and densification of fill due to drilling, hole collapse and excessive grout loss. Care should be taken to avoid ground settlement and damage to adjacent facilities, e.g., by limiting the number and spacing of open drillholes, specifying the use of permanent casing for drilling, or using pre-grouting. Ground movement and vibration monitoring may be warranted where there are sensitive structures or facilities like water-carrying services at the slope crest.

5.8.4 Soil-nail Reinforcement

The allowable capacity and pullout resistance of the soil nails should be determined in accordance with the guidance given in [Section 5.6.3\(2\)](#). Considerations on diameter, length, spacing and inclination given in [Sections 5.6.3\(3\)](#) to [5.6.3\(6\)](#) are also applicable.

5.9 PRESCRIPTIVE DESIGN OF SOIL NAILS IN EXISTING SOIL CUT SLOPES AND RETAINING WALLS

Soil nails can be designed prescriptively for stabilising existing soil cut slopes and retaining walls. Prescriptive measures are pre-determined, experienced based and suitably conservative modules of works prescribed to improve the stability of a feature without detailed ground investigation and design analysis. The measures can be used for preventive maintenance, and urgent repair and upgrading works for soil cut slopes and retaining walls. Nevertheless, the relevant qualifying criteria in the following aspects should be satisfied before the application of prescriptive measures:

- (a) type of works,
- (b) slope or wall geometry, and
- (c) consequence of failure.

Guidelines, including the qualifying criteria, on prescriptive design using soil nails for existing soil cut slopes and retaining walls are presented in GEO Report No. 56 (Wong et al, 1999), GEO Report No. 165 (Lui & Shiu, 2005) and GEO Technical Guidance Note No. 9

(GEO, 2004a).

As no ground investigation is carried out, the aggressivity of the soil at a site should be classified based on an assessment of the site setting, development history, and the nature and extent of utilities affecting the site (see [Section 4.3.2](#)). The design of corrosion protection measures should follow the guidance given in [Section 5.5](#). For “potentially aggressive” sites without soil aggressivity assessment, Class 1 corrosion protection measures should be provided to soil nails with a design life more than 2 years.

The design of slope facing should follow the general guidance given in [Section 5.6.5](#).

5.10 DRAINAGE PROVISION

Surface water runoff and existing groundwater conditions should be properly controlled to ensure satisfactory performance of a soil-nailed system, both during construction and throughout its design life. Concentrated surface water flows may result in erosion, washout failures, or shallow landslides. Build-up of high groundwater pressures behind the system may result in reduction of its overall stability. High groundwater levels may also adversely affect the grout quality as well as accelerate the corrosion rate of steel reinforcement. Suitable surface drainage provisions, e.g., crest channels with upstand and stepped channels, and subsurface drainage provisions, e.g., raking drains, should be provided to soil-nailed systems based on the actual site conditions.

A detailed appraisal of the likely flowpaths of surface runoff and the potential for concentration of surface water flow affecting the slope or retaining wall should be undertaken to facilitate design of the surface drainage system. Sufficient redundancy should be allowed for in the design based on engineering judgement, with due regard given to the site environmental setting and consequence in the event of blockage of the surface drainage channels. Guidance on the design of surface drainage channels is given in the Geotechnical Manual for Slopes (GCO, 1984). Reference should be made to GEO Technical Guidance Note No. 27 (GEO, 2006) on the design of stepped drainage channels.

In the case of fill slopes, adequate surface drainage measures, e.g., crest channels with upstand, should be provided to minimise the potential ingress of water into the fill body. Appropriate subsurface drainage measures are also essential to prevent the development of high base or perched groundwater levels. Leakage from water-carrying services will adversely affect the stability of a fill slope. Where such services are present within or above the fill body, actions should be taken to reduce the risk of leakage following the guidance given in the Geotechnical Manual for Slopes (GCO, 1984), Geoguide 5 : Guide to Slope Maintenance (GEO, 2003) and Code of Practice on Monitoring and Maintenance of Water-carrying Services Affecting Slopes (ETWB, 2006).

Provision of subsurface drainage behind a hard slope facing should be considered if there is a concern about the build-up of water pressure behind the facing.

Prescriptive subsurface drainage measures, such as raking drains, as contingency provisions are prudent in view of the innate variability of groundwater conditions. This is especially relevant in colluvial and saprolitic ground profiles and where a hard slope surface

cover is to be replaced with a vegetated cover. Designers should exercise due judgement in prescribing the necessary subsurface drainage measures. As a guide, situations where prescriptive subsurface drainage measures may be warranted include:

- (a) locations with evidence of seepage from the slope face,
- (b) at the interface of materials with significant permeability contrast giving rise to the potential for perching,
- (c) where there is a sizeable catchment draining towards the slope,
- (d) the presence of buried stream courses or subsurface drainage concentrations within the slope or in its vicinity with the possibility of lateral drainage towards the slope,
- (e) slopes whose stability is especially sensitive to changes in design groundwater levels,
- (f) as contingency provisions against possible leakage from nearby water-carrying services, and
- (g) where there is concern about possible damming effects of closely-spaced soil nails on groundwater flow.

Nonetheless, when specifying prescriptive subsurface drainage, care should be exercised to ensure that the lowering of the groundwater table will not be detrimental to nearby structures, facilities or services.

Guidance on the prescriptive design of a subsurface drainage system is given in GEO Report No. 56 (Wong et al, 1999).

During construction, sufficient temporary drainage should be provided at all times, especially during the wet season, to avoid any adverse effects of uncontrolled concentrated water ingress or surface water flow. The temporary site drainage should be regularly maintained and cleared of any blockage to ensure that the drains remain functional during heavy rainfall. The contractor should be encouraged, or required where appropriate, to construct part of the permanent drainage measures, e.g., crest drain and the associated discharge points, at an early stage of the works to enhance the temporary drainage provisions. During the construction of subsurface drains, due attention should be paid to avoid damaging the installed soil nails adjacent to the drains.

5.11 AESTHETICS AND LANDSCAPE TREATMENT

The principles of aesthetics and landscape treatment of un-reinforced slopes are generally applicable to soil-nailed systems. The appearance of soil-nailed systems should be compatible with and cause minimal visual impact to the existing environment. Designers should try to make the finished soil-nailed systems appear as natural as possible. One

important consideration is to identify and preserve, wherever practical, mature trees on slopes in particular those near the crest and toe of the slopes. Vegetation should always be considered as the first choice of surface cover on soil cut and fill slopes subject to considerations of safety and maintenance. Where a vegetated solution is not possible, designers should consider the visual treatment of the erosion control technique to be adopted. On steep soil slopes, the use of an erosion control mat and a steel wire mesh structurally connected to the soil-nail heads is recommended (see also [Section 5.6.5](#)). Care should be taken in the choice of planting techniques on steep slopes to ensure that the erosion control capability of the matting is not compromised.

The use of vegetation, particularly on steep soil-nailed slopes, carries a risk of occasional and small-scale failure. This may, for instance, take the form of shallow washout on soil slopes. The risk of small-scale failure should be balanced against the benefit of providing a greener and more aesthetically-pleasing slope, and appropriate mitigation measures should be provided where necessary. Buffer zones, catch fences or landslide debris-resisting toe walls should be considered where the consequence-to-life category is high and the slope is steep; or where it could be prone to large volumes of surface water runoff, i.e., a large catchment above the slope or where the slope intersects a valley. General guidance on slope greening and landscape treatment is given in GEO Publication No. 1/2000 : Technical Guidelines on Landscape Treatment and Bio-engineering for Man-made Slopes and Retaining Walls (GEO, 2000b). Information on vegetation species suitable for slope planting can be found in the booklet “Tree Planting and Maintenance in Hong Kong” published by Information Services Department (HKG, 1991) and in GEO Technical Guidance Note No. 20 (GEO, 2007b).

Attention should also be paid to the design and location of features such as surface drainage channels, stairways and catchpits in order to minimise their visual impact. Concrete aprons on either side of drainage channels, or in some cases the entire surface drainage system, can be designed using geotextiles or other bio-engineering techniques. Stairways should be routed with care to minimise visual impact with their widths reduced as far as possible and railings painted in sympathetic un-obtrusive colours.

Soil nails are visually more acceptable if they are placed in a regular rather than a random pattern. The layout of soil nails should complement the plan of preservation and protection of trees on the slopes or wall trees on the retaining walls. Soil nails and other engineering features should be located away from tree trunks and roots. Tree rings should be used to retain existing trees where a hard surface is required. Where possible, isolated soil-nail heads should be recessed and treated with a matt paint of a suitable colour to give a less intrusive visual appearance. An erosion control mat laid over soil-nail heads and recessed into the slope can also help to reduce their visual prominence. Typical details of recessed soil-nail heads are given in [Figure 5.11](#).

5.12 DESIGN OF SOIL NAILS IN SPECIFIC CIRCUMSTANCES

5.12.1 General

The design guidance given in [Sections 5.3](#) to 5.11 is specific to the design of soil nails that are used to carry transient loads in slopes and retaining walls, and where there is no sign

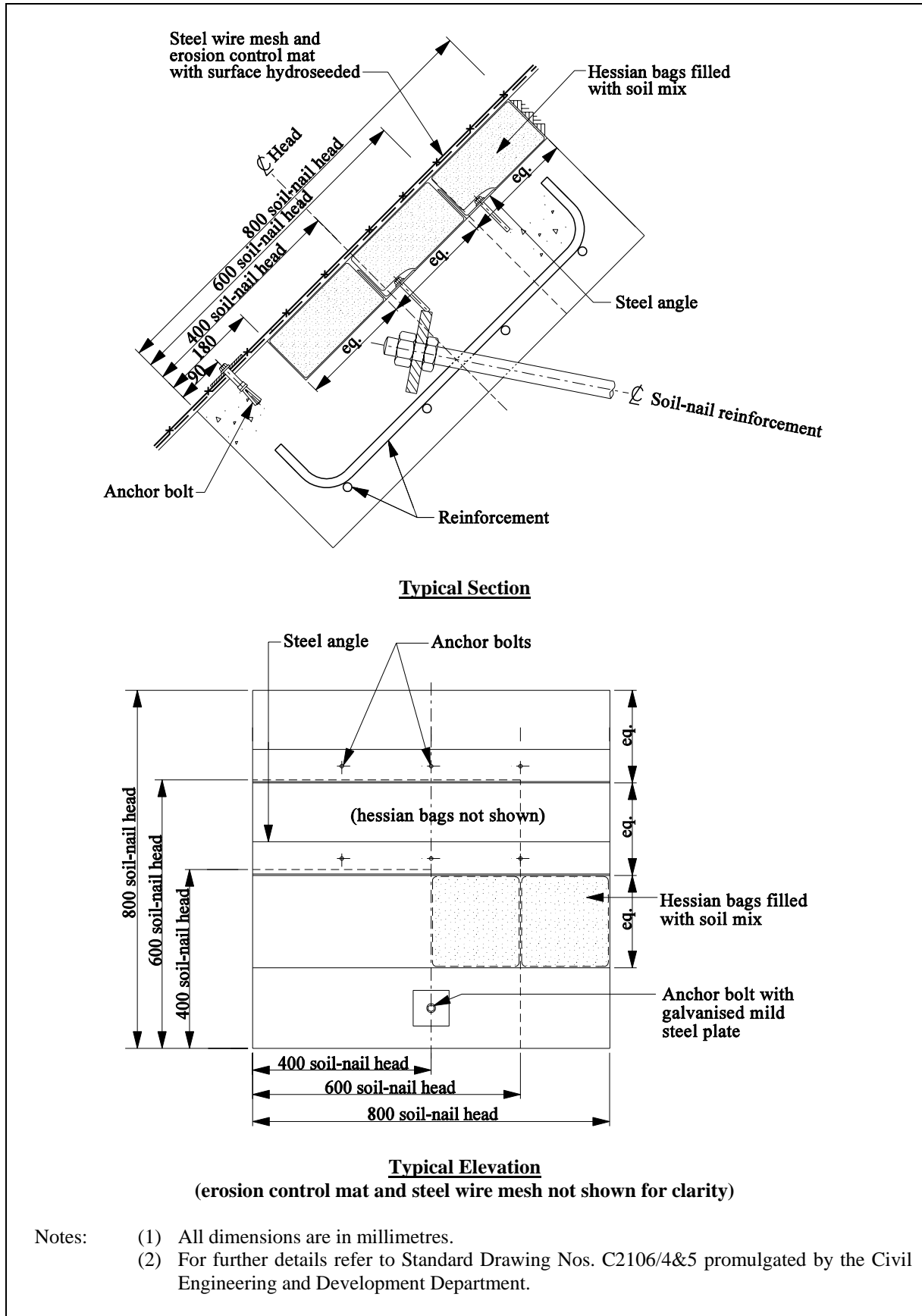

Figure 5.11 Typical Details of a Recessed Soil-nail Head

of continuous ground deformation. This guidance, in particular the design considerations regarding serviceability, durability, drainage provision, aesthetics and landscape treatment, is also applicable in general to other areas of application. Nevertheless, additional design guidelines and requirements given in the following sections should be followed under some specific circumstances.

5.12.2 Design of Soil Nails Carrying Sustained Loads

Soil nails that are designed to carry sustained loads require special considerations in respect of serviceability and durability. Soil nails in a system should be assumed to carry sustained loads if the stability of the system cannot be maintained without the continued action of the soil nails. The guidance given below is applicable to soil nails where the sustained loads are mobilised naturally through the interaction between the ground and the soil nails.

Because soil nails carrying sustained loads are usually associated with ground deformation and are more prone to creeping, in particular where the soil nails are bonded in ground with a high content of fines, a deformation analysis should be carried out (see [Section 5.4](#)). Susceptibility to creep should be determined by creep tests in accordance with [Section 6.3.3](#) if the soil nails are designed to bond in soil. For soil nails that are used for carrying sustained loads in permanent cases, a performance review of the completed soil-nailed system should be carried out prior to substantial completion of the project to confirm its long-term stability.

Steel reinforcing bars under sustained loads are more susceptible to corrosion than those carrying transient loads. Hence, more stringent corrosion protection measures should be provided. The recommended corrosion protection measures given in [Table 5.9](#) for soil nails carrying sustained loads should be followed.

Table 5.9 Recommended Corrosion Protection Measures for Soil Nails Carrying Sustained Loads

Design Life	Soil Aggressivity Classification			
	Highly aggressive	Aggressive	Mildly aggressive	Non-aggressive
Up to 120 years	Class 1			Class 2
Up to 2 years ^(Note 2)	Class 3			

Corrosion Protection Measures:

Class 1 - Hot-dip galvanising with a minimum zinc coating of 610 g/m² and corrugated plastic sheathing

Class 2 - Hot-dip galvanising with a minimum zinc coating of 610 g/m² and 2 mm sacrificial thickness on the radius of the steel reinforcement

Class 3 - Hot-dip galvanising with a minimum zinc coating of 610 g/m²

Notes: (1) For “potentially aggressive” sites without soil aggressivity assessment, Class 1 corrosion protection measures should be provided to soil nails with a design life more than 2 years.
(2) Soil aggressivity assessment is not required for soil nails with a design life up to 2 years.

Monitoring of the deformation of the soil-nailed system and the loads mobilised along representative soil nails should be carried out during construction and for a considerable period after construction, typically at least two wet seasons, in order to validate the design assumptions and to make design changes if necessary. Monitoring of piezometric pressures should also be carried out to aid the interpretation of the deformation data. Where the soil nails are used in temporary works, deformation monitoring should be carried out until the service of the soil nails is no longer required. Monitoring of the load in these soil nails is generally not warranted.

5.12.3 Design of Soil Nails in Temporary Excavations

The guidance given in [Section 5.6](#) for design of permanent soil-nailed cut slopes is generally applicable for the design of soil nails in temporary cuts. The factors of safety required should be the same as those for permanent new slopes, but with due regard for the groundwater and loading conditions that are likely to exist during the life of the temporary works.

Special care should be exercised in planning and designing a staged cut where the height of the exposed slope face should be determined on the basis of its stability, particularly before the construction of soil-nail heads. Soil-nail heads and facing should be constructed before proceeding to the next stage of excavation. Some large landslides have occurred in temporary cuts in which soil nails were installed but without soil-nail heads.

If the temporary cut involves soil nails carrying sustained loads, the guidance given in [Section 5.12.2](#) should be followed. A deformation analysis is required if the deformation of the soil-nailed excavation may cause damage to nearby structures, facilities, services and land.

If the temporary excavation involves the use of structural lateral support, soil nails can serve as tie-backs. The guidance given in [Sections 5.3, 5.4 and 5.5](#) on design of soil nails is generally applicable. Soil nails may be modelled as structural elements providing external forces to the stem wall of the lateral support system. The guidance given in GCO Publication No. 1/90 : Review of Design Methods for Excavations (GCO, 1990) on the design of lateral support should be followed.

Because the experience of using soil nails in temporary excavation in cohesive soils in Hong Kong is limited, special care should be exercised about the effect of creeping on the stability and serviceability of the excavation, in particular if the soil nails are designed to carry sustained loads.

5.12.4 Design of Soil Nails using Alternative Reinforcement Materials

Although solid high yield deformed steel bars are commonly used for soil-nail reinforcement, reinforcement of other types of materials may be considered. A brief description of the available alternative reinforcement materials is summarised as follows.

(1) *Fibre Reinforced Polymer*. Fibre reinforced polymer or fibre reinforced plastic (FRP) is a composite material made of fibres embedded in a polymeric resin of thermoset or

thermoplastic. The fibres commonly used in the composites for civil engineering include carbon, glass and aramid. FRP reinforcement has advantages over steel bars in having high tensile strength, light weight and good corrosion resistance. However, drawbacks of this material include its low bending and shear capacity as well as its brittle behaviour during failure. The local laboratory material test and site pullout test data of the carbon fibre reinforced polymer (CFRP) reinforcement, and the interim guidance on the design and construction of CFRP soil nails is discussed by Cheung & Lo (2005).

(2) *Stainless Steel*. A range of stainless alloy types is available for the selection of soil-nail reinforcement to meet the mechanical aspects and the expected soil aggressivity. Stainless steels are produced in five alloy groups, namely austenitic, ferritic, duplex, martensitic and precipitation hardened. Different groups have different microstructures, which are dictated by the chemical compositions and the production steps involved. For stainless steel reinforcing bars, austenitic and duplex alloys have generally received the most attention. Recently, a hybrid of high yield deformed steel and stainless steel bars has become available in which the deformed steel bars are fused by a stainless steel cladding. An advantage of stainless steel reinforcement is its good corrosion resistance while the ductile behaviour of steel is retained. In addition, as no reinforcement coating is involved, there is neither need to have special treatment for the exposed cut ends nor any risk of damage to the coating. The cost of stainless steel is high and there is little experience on the use of stainless steel cladding bars in Hong Kong.

(3) *High Tensile Steel Strand and Bar*. High tensile steel strand reinforcement is commonly used in prestressed ground anchors. One advantage of using this material in soil nailing is its flexibility, which enhances the installation particularly at sites of limited working space. Similar to high yield deformed steel bars, high tensile steel strand and bar are susceptible to corrosion. Suitable corrosion protection measures have to be used in conjunction with the reinforcement. The interaction between the ground and flexible steel strand reinforcement is not well understood.

The alternative reinforcement materials as listed above are not exhaustive.

In assessing the suitability of a material as an alternative to high yield deformed steel bar for soil-nail reinforcement, designers should give due consideration to the merits and limitations of using the material under the design and construction requirements. For example, due to the lack of ductile failure behaviour of fibre reinforced polymer materials, a very high factor of safety against tensile failure may be required and thus renders its use uneconomical for most applications. Although some of these alternative materials have been used as soil-nail reinforcement overseas, their application in Hong Kong is limited. If these materials are to be used as soil-nail reinforcement, the following factors should be considered in the design:

- (a) capacity under combined actions of tension, shear and bending,
- (b) susceptibility to bending or shear failure,
- (c) strain compatibility between the material and the ground,

- (d) bond strength between the material and the cement grout,
- (e) ductility under combined actions of tension, shear and bending,
- (f) long-term durability,
- (g) special requirements for transportation, storage and handling of the material on site,
- (h) the need for compliance tests, and
- (i) maintenance and monitoring requirements.

6. CONSTRUCTION

6.1 GENERAL

It is of paramount importance that the quality of materials and workmanship of soil nailing works meet the design requirements. Designers should incorporate into the contract documents sufficient control measures to ensure that during construction there will be adequate geotechnical supervision, testing and monitoring commensurate with the scale and complexity of the particular project.

Proper supervision and control are required during all stages of soil nailing works, particularly those aspects of works that are difficult to be verified afterwards, e.g., length of installed soil nail, integrity of couplers and corrosion protection measures. Site supervisory staff should be provided with sufficient information and briefing for their appreciation of the geotechnical content of the works, key design assumptions and the range of potential anomalies that could be encountered. It is the designer's responsibility to review the validity of the assumptions critical to the design during the construction of works. Nevertheless, the site supervisory staff should inform the designer if the actual conditions are found to deviate significantly from those assumed.

Development and verification of the design should continue during construction stage when further information on the actual ground and groundwater conditions is available. This may lead to refinements of the original design. GEO Publication No. 1/2007 : Engineering Geological Practice in Hong Kong (GEO, 2007a) presents the importance of engineering geological input and related good practice in Hong Kong.

The general guidance on the aspects of construction control is outlined in Chapter 9 of Geotechnical Manual for Slopes (GCO, 1984) and Chapter 12 of Geoguide 1 : Guide to Retaining Wall Design (GEO, 1993). Further guidance specific to soil nailing works is covered in this Chapter.

6.2 CONSTRUCTION SUPERVISION AND CONSIDERATIONS

6.2.1 General

It is important to supervise, inspect and keep accurate records of all the construction activities of soil nailing works because once the soil nails are installed, their quality is not readily visible. All soil nailing works should be supervised by personnel with suitable qualifications and experience. In general, full-time supervision should be accorded to all soil nailing works with some aspects such as pullout tests, insertion of soil-nail reinforcement and grouting to be individually inspected and checked by the site supervisory staff. The more important aspects of supervision during soil nailing works are summarised below:

- (a) undertaking inspections of soil-nail reinforcement and its accessories for size, grade, length, corrosion protection measures and integrity, and to check that all the soil-nail components are assembled to the requirements of the

specification,

- (b) checking to ensure that the soil nails, in particular their length, inclination and spacing, are constructed in accordance with the design,
- (c) monitoring and keeping records of the installation and testing operations of the soil nails, in particular the ground and groundwater conditions encountered during drilling, the volume of grout intake at a sustained low pressure head and the process of pullout tests,
- (d) assessing the safety and adequacy of the methods used in constructing the soil nails, and of the construction sequence, in particular for a cut supported by soil nails,
- (e) assessing the safety of temporary works and the effects of such works on the slope or the cut, and the nearby ground, structures, facilities and services, and
- (f) identifying non-compliance with the specification or agreed method statements for temporary or permanent works and rectifying the situation promptly.

For public works projects, the guidance and requirements for the supervisory personnel are stipulated in the Project Administration Handbook (CEDD, 2006b). The requirements for material and workmanship are given in the General Specification for Civil Engineering Works (CEDD, 2006a). For private projects, the requirements are stipulated in the Code of Practice for Site Supervision 2005 (BD, 2005a) and the Technical Memorandum for Supervision Plans 2005 (BD, 2005b) issued by the Buildings Department. A sample checklist providing general questions that may need to be addressed when constructing soil nails is given in [Figure 6.1](#). The checklist should be modified to suit individual situations and contract requirements. Some important issues in relation to those major construction activities are provided in the following Sections.

6.2.2 Drilling

The correctness of the alignment of drillholes is important in the prevention of clashing of soil nails, in particular for closely-spaced or long soil nails, or soil nails with different inclination and bearing. It is common practice to check the correctness of the inclination and bearing of drillholes by using a protractor and compass on the drill rods. It is of paramount importance to control and check the initial inclination and bearing of drillholes. If accurate measurements of the inclination and bearing of the drillhole along its length are needed, special equipment such as an Eastman camera may be employed.

For drilling long soil nails, the drill rate should be suitably controlled to minimise the eccentricity produced by the dip of the drill rods, which may otherwise cause misalignment of the drillhole or may unduly enlarge the diameter of the drillhole and cause hole collapse.

No.	Activities	Findings			Remarks
	Description	Yes	No	N/A	
1	Pre-construction Review				
1.1	Any approved drawings, geotechnical design reports and specification?				
1.2	Any approved method statements providing construction procedures and sequences of works?				
1.3	Any material requirements, construction tolerances and acceptance/rejection criteria?				
1.4	Any compliance testing requirements to ensure the quality of the works?				
1.5	Any monitoring requirements to check the performance of the works?				
1.6	Any temporary works required to facilitate the construction of the permanent works?				
1.7	Any pre-construction site trial to assess the buildability of the works?				
2	Setting Out				
2.1	Are the positions of the soil nails in agreement with the contract requirements?				
2.2	Have the positions of the soil nails been checked to see whether any existing utilities, channels, surface boulders, trees, foundations and other structures or any proposed works such as surface channel and subsurface drains would be affected?				
3	Drilling				
3.1	Has the drilling equipment (type, diameter of drill bit, total length of drill rods, flushing medium, etc.) been checked?				
3.2	Has the water, dust, fumes and noise generated during drilling operation been sufficiently diverted, controlled, suppressed and muffled?				
3.3	Have the drilling works on working platforms which are visible to nearby residents been shielded from view by tarpaulin sheets?				
3.4	Any requirement on use of permanent or temporary casing?				
3.5	Are there any freshly grouted soil nails near the drillhole to be drilled?				

Figure 6.1 Sample Checklist for Soil Nail Construction Control (Sheet 1 of 4)

	Activities	Findings			Remarks
No.	Description	Yes	No	N/A	
3.6	Are the drillhole diameter, length, inclination and bearing in accordance with the contract requirements?				
3.7	Has the Contractor suitably controlled the drill rate to minimise the eccentricity produced by the dip of the drill rods when drilling long soil nails?				
3.8	Have random checks been carried out on the correctness of the inclination and bearing of the drillhole during drilling?				
3.9	Are there any anomalies among the ground and groundwater conditions?				
4	Assembly of Soil-nail Reinforcement				
4.1	Are the soil-nail components, including reinforcement, grout pipes, centralisers, reinforcement connectors, corrugated plastic sheathing, heat-shrinkable sleeve, washers, nuts, bearing plates and conducting wires (for NDT) of the correct type, grade, length and size?				
4.2	Are the centralisers adequate to support the reinforcement and ensure minimum grout cover?				
4.3	Have the reinforcement connectors been inspected for tightness after assembly?				
4.4	Are the grout pipes straight, free from blockage, without side holes (except near the end of the pipe as specified in the contract) and extended to the end of the soil nails?				
4.5	Are the corrosion protection measures to reinforcement and reinforcement connectors in accordance with the contract requirements and have been inspected for integrity?				
4.6	Has the assembling method been verified by site trials for not causing damage, deformation and displacement to the soil-nail components on completion of assembly, during inserting and withdrawing the soil nails?				
5	Installation				
5.1	Have the drillholes been left open for a time longer than that permitted in the contract?				
5.2	Is there any constant flow of water coming out from the drillhole?				

Figure 6.1 Sample Checklist for Soil Nail Construction Control (Sheet 2 of 4)

	Activities	Findings			Remarks
No.	Description	Yes	No	N/A	
5.3	Have the drillholes been cleared of debris and standing water immediately before installation of reinforcement?				
5.4	Has the correct assembly of the soil-nail reinforcement been inserted?				
5.5	Have obstructions been encountered during insertion of reinforcement into the drillhole?				
5.6	Has a minimum clearance, in accordance with the contract requirements, been maintained between the distal end of the reinforcement and the bottom of the drillholes after installation?				
6	Grouting				
6.1	Is the grout mix in accordance with the contract requirements?				
6.2	Has the grout operation been carried out in accordance with the method statement?				
6.3	Has the grouting of soil nails been carried out on the same day as the soil nail installation?				
6.4	Have the water, dust, fumes and noise generated during the grouting operation been sufficiently diverted, controlled, suppressed and muffled?				
6.5	Is there any excessive grout take?				
6.6	Is the grout that has returned from the top of the drillhole of satisfactory cleanliness and viscosity?				
6.7	Has a minimum pressure head in accordance with the contract requirements been maintained in the outlet pipe after completion of grouting until the cement grout has reached the initial set?				
7	Construction of Soil-nail Heads				
7.1	Are the soil-nail heads of correct size and the materials used in accordance with the contract requirements?				
7.2	Have the threads at the proximal end of reinforcement been thoroughly cleaned, properly treated with hot-dip galvanised coating, or protected with approved zinc-rich paint prior to construction of soil-nail heads?				
7.3	Has the placed concrete been adequately compacted to avoid honeycombing?				

Figure 6.1 Sample Checklist for Soil Nail Construction Control (Sheet 3 of 4)

	Activities	Findings			Remarks
No.	Description	Yes	No	N/A	
7.4	Has the concreting of the soil-nail heads been divided into two stages when using sprayed concrete?				
7.5	Have the water, dust, fumes and noise generated during the concreting operation been sufficiently diverted, controlled, suppressed and muffled?				
7.6	Are there any anomalies on the workmanship of the soil-nail heads which have been uncovered in accordance with the contract requirements?				
7.7	Has the corrugated plastic sheathing been embedded into the soil-nail heads in accordance with the contract requirements?				
8	Pullout Test				
8.1	Have adequate test soil nails being installed for pullout test?				
8.2	Has the pullout test equipment been set up in accordance with the contract requirements?				
8.3	Any necessity for carrying out a creep test?				
8.4	Have the test soil nail drillholes been fully grouted after completion of the tests?				
9	Excavation				
9.1	Is the excavation and the soil nail construction sequence in accordance with the method statement?				
9.2	Have the soil nails and soil-nail heads been constructed in time?				
9.3	Has the excavation surface been protected from water ingress and surface erosion?				
9.4	Are the temporary drainage provisions adequate?				
9.5	Any excessive movement affecting the stability of the excavation or nearby facilities?				
10	Site Supervision				
10.1	Has the required qualified supervision (e.g., Category I and Category III site supervision) been provided by the Government department or geotechnical consultant for public projects and Registered Geotechnical Engineer for private projects, in particular at the critical stages of the soil nailing works?				

Figure 6.1 Sample Checklist for Soil Nail Construction Control (Sheet 4 of 4)

Under special circumstances, such as drilling through a zone of loose material, casing may be used to enhance buildability. Drillholes in soil should be kept open only for short periods of time. The longer the hole is left open, the greater the risk of collapse.

Drilling under water should be cautious because the hole is more susceptible to collapse than one in dry ground. It may also cause disturbance to the adjacent ground, which will weaken the bond strength between the ground and soil nail. In difficult ground conditions, suitable dewatering measures may have to be considered to facilitate the drilling of soil nails. The effects of any dewatering should be duly assessed and mitigation measures taken as appropriate.

Before drilling works in a reinforced concrete wall is carried out, safety precautions should be implemented to avoid damaging steel bars in the reinforced concrete wall, such as using metal detector to determine locations of steel bars.

Advanced techniques such as Drilling Process Monitoring (DPM) (Yue et al, 2004) may be used in recording information on the hole drilling process.

6.2.3 Installation of Soil-nail Reinforcement

The integrity of corrosion protection measures such as hot-dip galvanising, corrugated plastic sheathing and heat-shrinkable sleeves should be checked prior to insertion of soil-nail reinforcement. Pitting spots should not be tolerated as this may lead to severe corrosion under aggressive ground conditions.

Drillholes should be kept clean, otherwise the integrity of the cement grout sleeve will be affected. Simple tools such as a mirror and a high intensity light are generally good enough for inspecting the drillhole for cleanliness. For long drillholes, closed-circuit television (CCTV) may be used. If obstructions are encountered during insertion of soil-nail reinforcement into the drillhole, the reinforcement should be withdrawn and the obstruction should be removed before the reinforcement is re-inserted.

During insertion of the soil-nail reinforcement, the reinforcement should not be pushed completely to the bottom of the drillhole. A minimum clearance as specified by the designer should be maintained between the end of the reinforcement and the bottom of the drillhole so that there is adequate cement grout covering to the soil-nail reinforcement.

6.2.4 Grouting

Grouting should be carried out as soon as possible, for example, on the same day when the soil-nail reinforcing bars are inserted into the drillholes, to minimise the potential for hole collapse. Grouting, using a grout pipe inserted to the bottom of the drillhole, should continue until the cement grout emerging from the top of the hole is uncontaminated. This helps to ensure good integrity of the cement grout sleeve. To compensate for possible grout leakage, a pressure head, typically about 1 m above the mouth of the drillhole, should be maintained in the cement grout sleeve after completion of grouting until the cement grout has reached the initial set.

Excessive grout leakage implies difficulty in forming an intact cement grout sleeve. Excessive migration of cement grout may also increase the risk of groundwater damming and ground contamination. It is good practice to monitor the amount of cement grout take by recording the volume of cement grout placed in each drillhole. In case of excessive grout take, the designer should be notified promptly in order to determine the action to be taken, such as adoption of staged grouting and sleeving over the location of grout leakage using casing. In addition, the designer should review the validity of the assumed design model so as to assess whether any changes in design are necessary.

For grouting of soil nails with corrugated plastic sheathing, excessive deflection and distortion of the sheathing between supports may occur if the inner annular space between the wall of sheathing and soil-nail reinforcement is grouted first and the centralisers are not strong enough to support the weight of the wet grout. Appropriate measures should be taken to prevent floating of the sheathing if grouting is first carried out in the outer annular.

Grouting under water should be avoided as far as practicable because the integrity of cement grout may be adversely affected. Provisions of dewatering measures, e.g., by raking drains, should be incorporated in the design if it is expected that the grouting operation would be affected by groundwater. Where the drillholes intrude upon a persistent groundwater regime unexpectedly, dewatering measures should be implemented prior to the grouting operation. The effects of any dewatering on adjacent ground and facilities should be duly assessed and mitigation measures should be taken to alleviate the effects as appropriate.

6.2.5 Construction of Soil-nail Heads

Particular attention should be paid to ensure the integrity of soil-nail heads, especially at the location beneath the bearing plate where honeycombing is not uncommon. It is good practice to construct soil-nail heads in two stages if sprayed concrete is used. The first stage concreting should be applied to a specified thickness above the intended base level of the steel bearing plate. The bearing plate should then be hammered into place and the nut tightened onto the soil-nail reinforcement before the application of the second stage concreting. If necessary, some soil-nail heads should be uncovered as a quality check.

6.2.6 Excavation Sequence

Soil-nailed excavation is usually carried out in stages. The height of the exposed slope face is determined on the basis of its temporary stability. After installation of a row of soil nails, subsequent excavation should progress only when the temporary stability of the excavation is adequate. Soil-nail heads and facing should be constructed before the next stage of excavation unless the temporary stability of the soil-nailed excavation in the absence of soil-nail heads is adequate (see [Section 5.12.3](#)). The sequence and timing of installing soil nails, constructing soil-nail heads and facing, and excavation should be monitored and controlled to fulfil these requirements.

6.3 TESTING

6.3.1 Material Compliance Testing

All the materials used for the construction of soil nails should comply with the design and specification requirements. Material compliance tests should be carried out on representative samples to verify the quality of materials. For cement grout, testing for crushing strength, bleeding and flow cone efflux time is required and for soil-nail reinforcement, tensile test, bend test and re-bend test should be carried out. For public works projects, the testing requirements, sampling frequency and acceptance criteria are stipulated in the General Specification for Civil Engineering Works (CEDD, 2006a).

6.3.2 Pullout Test

The primary objective of field pullout test is to verify design assumptions about the bond strength at the interface between the ground and the cement grout sleeve. The test also gives an indication of the contractor's workmanship, the appropriateness of the construction method under the specific ground and groundwater conditions, and potential construction difficulties. Pullout tests should, as far as practicable, be carried out at locations where the pullout resistance may be low or the buildability of the soil nails is most uncertain, e.g., at locations of relatively weaker material or high groundwater level. Pullout tests should be carried out prior to the construction of working soil nails so that the information gathered from the tests can be reviewed for making design changes as needed.

The test soil nails should be installed using the same procedures as the working soil nails except that only the bottom part of the soil nail is grouted. In Hong Kong, the length of the cement grout sleeve of test soil nail is typically 2 m. Too short a bond length may not be adequately representative whereas a long bond length requires a large pullout load and hence heavy equipment and set-up. Nevertheless, designers may specify a bond length other than 2 m to suit particular test objectives.

It is good practice to collect additional information such as the type of material encountered and the presence of groundwater during hole drilling in order to learn more about site-specific ground conditions.

Soil nails for pullout tests require partial grouting of the drillholes to form the specified bond length for testing. Grouting should be carried out slowly and carefully to prevent over-grouting. Packers are usually used to seal off the grouted section. Many types of packers such as inflatable packers are available. Only packers that can effectively seal off the grouted section should be used. The packers should, as far as practicable, not contribute to the bond strength of the grouted section, or otherwise the contribution should be taken into account in the estimation of bond strength. Apart from packer, time domain reflectometry technique can be used to determine the length of the grouted section during the grouting process with reasonable accuracy.

When setting up the pullout test apparatus, the steel bearing plate to be used for the test should not be allowed to bear down onto the steel bar as this will deflect the bar, thereby giving incorrect readings during the test. A frictionless support should also be provided to

the test apparatus in order to minimise the friction loss due to jacking motion. A sample of a test apparatus and set-up is shown in Figure 6.2.

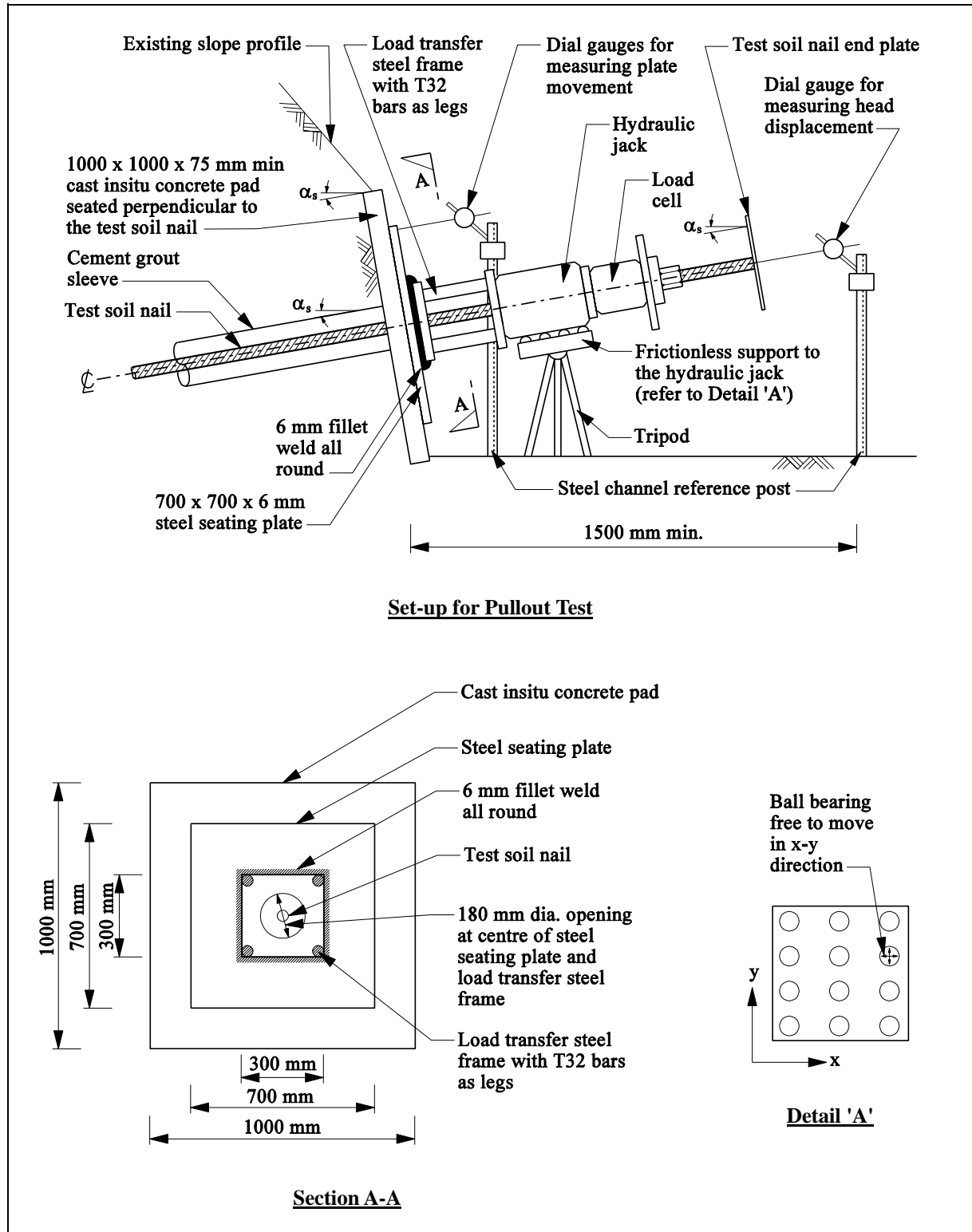

Figure 6.2 Set-up for a Pullout Test

It is common practice to set the number of pullout tests as 2 % of the total number of working soil nails subject to a minimum of two. However, designers should exercise engineering judgement to ensure that the number of pullout tests is sufficient and representative to meet the test objectives. Typical testing procedures and acceptance criteria are given in [Figure 6.3](#).

As the integrity of soil nails subjected to a pullout test may be damaged during the test, they should be taken as sacrificial and be filled up by cement grout upon completion of the test, i.e., they should not form part of the permanent works. Working soil nails should not be used for pullout tests because the integrity of the cement grout sleeve may be damaged during the test. The results are also misleading because part of the pullout resistance is attributed to the ground-grout bond in the active zone.

6.3.3 Creep Test

For soil nails designed to carry sustained loads and bonded in soil, a creep test should be carried out to determine the susceptibility of long-term creep of the soil nails. The test may be carried out as part of a pullout test. The number of creep tests may be the same as that for pullout tests. Nevertheless, designers should exercise engineering judgement about the sufficiency and representativeness of the tests in meeting the test objective. Typical procedures and acceptance criteria of the test are given in [Figure 6.4](#).

In the event that the acceptance criteria cannot be met by any of the creep tests, the design bond strength of the soil nails, which the creep test represents, should be reviewed and revised as needed. In some situations, the bonded zone may have to be relocated to a different geological material to achieve the required bond strength. New creep tests should be carried out if the design bond strength has changed.

6.3.4 Non-destructive Testing

Non-destructive testing (NDT) can encourage higher construction standards and promote self-imposed improvements in installation techniques and quality control. The test results can be used to build up an overall picture of the integrity of the installed soil nails.

NDT has been used in Hong Kong in assessing the length of steel bars and the integrity of the cement grout sleeve in installed soil nails, e.g., Time Domain Reflectometry (TDR) tests on soil nails with a pre-installed wire. Provided that the limitations of NDT are understood and allowed for, these tests can serve as a useful audit tool. Reference may be made to Lee & OAP (2007) on the NDT techniques commonly available in Hong Kong.

Among the potential NDT techniques that have been examined, TDR has proven reliability and was the simplest (Lee & OAP, 2007). There are other techniques that may be used to check the quality of installed soil nails. For acceptance of any new NDT technique for quality control, the technique should have a known and consistent basis for the interpretation of test results in addition to other considerations including reliability, scientific basis and limitations. Reference should be made to the GEO Technical Guidance Note No. 18 (GEO, 2004b) on the principles for acceptance of methods for quality control.

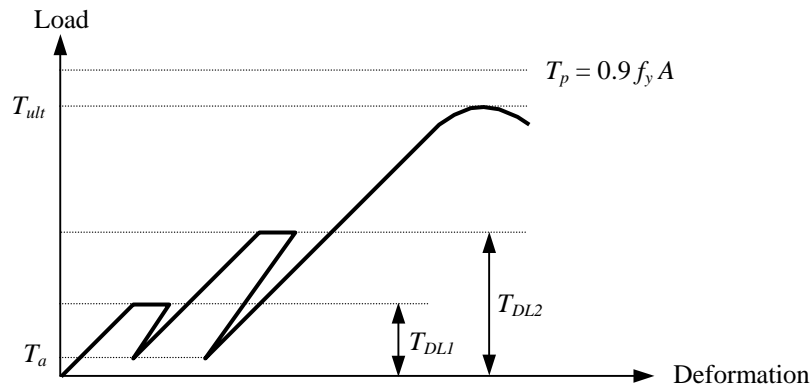

Schematic Diagram of Load-deformation Cycles of a Pullout Test

Testing Procedures

1. The test soil nail shall be loaded in stages: from the initial load (T_a) via two intermediate test loads (T_{DL1} and T_{DL2}) to the maximum test load.
2. T_{DL1} shall be the allowable pullout resistance provided by the bond length of the cement grout sleeve of the test soil nail.
3. T_{DL2} shall be T_{DL1} times the factor of safety against pullout failure at soil-grout interface (F_{SG}).
4. The maximum test load shall be 90 % of the yield load of the test soil-nail reinforcement (T_p) unless the ultimate ground-grout bond load (T_{ult}) is reached during the test. Reinforcement size larger than that of the working soil nail should be used in the pullout test, where necessary, to allow the development of T_{ult} prior to reaching T_p .
5. T_a shall be T_{DL1} or 5 % of T_p , whichever is smaller.
6. During the first two loading cycles, T_{DL1} and T_{DL2} shall be maintained for 60 minutes for deformation measurement. The measurement at each of the cycles shall be taken at time intervals of 1, 3, 6, 10, 20, 30, 40, 50 and 60 minutes. If the test soil nail can sustain the test load subject to the acceptance criteria given below, the load shall be reduced to T_a and the residual deformation shall be recorded, after which the test shall proceed to the next loading cycle.
7. In the last loading cycle, the test load shall be increased gradually from T_a straight to the maximum test load and then maintained for deformation measurement. The measurement shall be taken at time intervals of 1, 3, 6, 10, 20, 30, 40, 50 and 60 minutes. If the test soil nail can sustain the test load subject to the acceptance criteria given below, the load shall be reduced to T_a and the residual deformation shall be recorded, after which the test is completed.
8. If the test soil nail fails to sustain T_{DL1} , T_{DL2} , or the maximum test load in any cycle, the test shall be terminated and the soil nail movement against residual load with time shall be recorded. The measurements shall be taken at time intervals of 1, 3, 6, 10 and, every 10 minutes thereafter over a period for at least two hours. The measurements shall be taken for a longer period where considered necessary.

Acceptance Criteria

The test soil nail is considered to be able to sustain the test load if the difference of soil nail movements at 6 minutes and 60 minutes does not exceed 2 mm or 0.1 % of the bond length of the test soil nail.

Figure 6.3 Typical Procedures and Acceptance Criteria for a Pullout Test

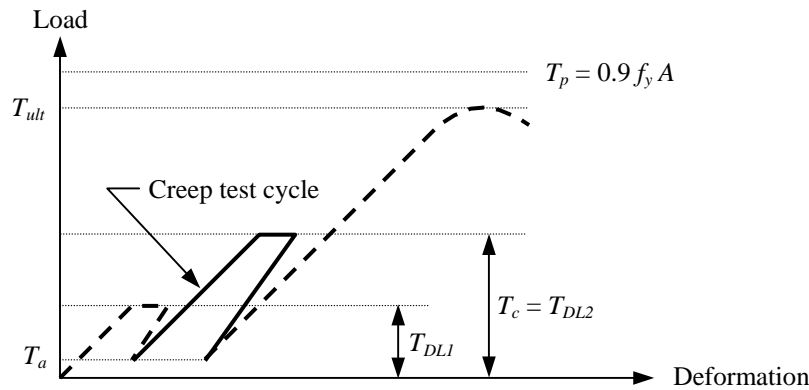

Schematic Diagram of Load-deformation Cycle of a Creep Test as part of a Pullout Test

Testing Procedures

1. The procedures for a creep test are similar to those for a pullout test except that only one loading cycle is required. Hence, it may be carried out as part of a pullout test. Typical procedures for a pullout test and the definition of T_a , T_{DL1} and T_{DL2} are given in Figure 6.3.
2. The test soil nail shall be loaded from T_a to the creep test load (T_c).
3. The creep test load (T_c) is defined as the allowable pullout resistance provided by the bond length of the cement grout sleeve of the test soil nail times the factor of safety against pullout failure at soil-grout interface (F_{SG}), which is corresponding to the intermediate test load T_{DL2} for a pullout test.
4. The creep period shall be deemed to begin when T_c is applied. The load shall be maintained for 60 minutes for deformation measurement. During the creep period, the measurement shall be taken at time intervals of 1, 3, 6, 10, 20, 30, 40, 50 and 60 minutes.

Acceptance Criteria

A test soil nail shall be considered acceptable when:

- (a) the difference of soil nail movements at 6 minutes and 60 minutes during the creep period does not exceed 2 mm or 0.1 % of the bond length of the test soil nail, and
- (b) the overall trend of creep rate (i.e., soil nail movement/log time) is decreasing throughout the creep period.

Figure 6.4 Typical Procedures and Acceptance Criteria for a Creep Test

6.3.5 Destructive Testing

Destructive testing of soil nails is seldom feasible. Where needed, destructive testing techniques such as stitch drilling, over-coring and excavation are occasionally adopted to exhume installed soil nails to check their lengths and built condition. However, it is difficult to control the alignment of drilling and coring with respect to that of the installed soil nail. Excavation to expose long and deeply buried soil nails may even be impractical.

7. MONITORING AND MAINTENANCE

7.1 GENERAL

This Chapter provides specific guidance on the monitoring and maintenance of soil-nailed systems. General guidance on the monitoring and maintenance of slopes and retaining walls, which is also applicable to soil-nailed systems, is given in Geotechnical Manual for Slopes (GCO, 1984) and Geoguide 5 : Guide to Slope Maintenance (GEO, 2003) respectively.

7.2 MONITORING

Monitoring is generally not required for a permanent slope or retaining wall reinforced by soil nails that carry transient loads. For soil nails that carry sustained loads, monitoring of the ground movement and loads mobilised along representative soil nails should be carried out during construction and for a considerable period, e.g., at least two wet seasons after construction. An inclinometer may be used to obtain the full vertical profile of the horizontal ground movement. Monitoring of piezometric pressures should also be carried out to aid the interpretation of deformation data. Where the soil nails carrying sustained loads are used in temporary structures, movement monitoring should be carried out until the service of the soil nails is no longer required. Monitoring of the load in these soil nails is generally not warranted.

Under normal circumstances, soil nails and the associated grouting will not have any significant adverse water-damming effect on the hydrogeological regime (HCL, 2007). However, in cases of excessive grout leakage, the cement grout could reduce significantly the permeability of the ground, and groundwater may be dammed up. If there is a concern about the occurrence of the water-damming effect, piezometers should be installed immediately behind the anticipated extent of the soil-nailed zone such that monitoring can be undertaken prior to and after soil nailing works to ascertain the effect. In planning the locations of piezometers, their potential of being blocked by the leaked grout should also be considered.

7.3 MAINTENANCE

The maintenance requirements for soil-nailed systems should follow the recommendations given in Geoguide 5 : Guide to Slope Maintenance (GEO, 2003). In particular, Geoguide 5 recommends that the frequency of Engineer Inspections for Maintenance should be once every five years for Consequence-to-life Category 1 and 2 slopes and once every ten years for Consequence-to-life Category 3 slopes. If the performance of a soil-nailed slope or retaining wall is confirmed to be satisfactory by a post-construction review, the frequency of Engineer Inspections for Maintenance may be reduced.

REFERENCES

- BD (2005a). *Code of Practice for Site Supervision 2005*. Buildings Department, Hong Kong, 104 p.
- BD (2005b). *Technical Memorandum for Supervision Plans 2005*. Buildings Department, Hong Kong, 31 p.
- BSI (1990). *Methods of Test for Soils for Civil Engineering Purposes (BS 1377: Parts 1 to 9: 1990)*. British Standards Institution, London, UK, 406 p.
- BSI (1997). *Structural Use of Concrete. Part 1 - Code of Practice for Design and Construction (BS 8110: Part 1: 1997)*. British Standards Institution, London, UK, 163 p.
- BSI (1999). *Hot Dip Galvanised Coatings on Fabricated Iron and Steel Articles - Specifications and Test Methods (BS EN ISO 1461: 1999)*. British Standards Institution, London, UK, 22 p.
- CEDD (2006a). *General Specification for Civil Engineering Works*. Civil Engineering and Development Department, Hong Kong.
- CEDD (2006b). *Project Administration Handbook*. Civil Engineering and Development Department, Hong Kong.
- Cheung, W.M. & Lo, D.O.K. (2005). Use of carbon fibre reinforced polymer reinforcement in soil nailing works. *Proceedings of the HKIE Geotechnical Division 25th Annual Seminar: Safe and Green Slopes*. The Hong Kong Institution of Engineers, Hong Kong, pp. 175-184.
- CIRIA (2005). *Soil Nailing - Best Practice Guidance*. Construction Industry Research & Information Association, London, UK, Report No. C637, 286 p.
- Clouterre (1991). *French National Research Project Clouterre - Recommendations Clouterre (English Translation 1993)*. Federal Highway Administration, US Department of Transportation, Washington, D.C., USA, Report No. FHWA-SA-93-026, 321 p.
- DOT (1994). *Design Methods for the Reinforcement of Highway Slopes by Reinforced Soil and Soil Nailing Techniques (HA 68/94)*. Department of Transport, UK.
- ETWB (2006). *Code of Practice on Monitoring and Maintenance of Water-carrying Services Affecting Slopes*. Environment, Transport and Works Bureau, Hong Kong, 93 p.
- Eyre, D. & Lewis, D.A. (1987). *Soil Corrosivity Assessment. (Contractor Report 54)*. Transport and Road Research Laboratory, Crowthorne, UK.

- FHWA (1998). *Manual for Design and Construction Monitoring of Soil Nail Walls*. Federal Highway Administration, US Department of Transportation, Washington, D.C., USA, Report No. FHWA-SA-96-069R, 530 p.
- FHWA (2003). *Geotechnical Engineering Circular No. 7 - Soil Nail Walls*. Federal Highway Administration, US Department of Transportation, Washington, D.C., USA, Report No. FHWA0-IF-03-017, 210 p.
- *GCO (1984). *Geotechnical Manual for Slopes. (2nd Edition)*. Geotechnical Control Office, Civil Engineering Services Department, Hong Kong, 295 p.
- *GCO (1987). *Guide to Site Investigation (Geoguide 2)*. Geotechnical Control Office, Civil Engineering Services Department, Hong Kong, 359 p.
- *GCO (1988). *Guide to Rock and Soil Descriptions (Geoguide 3)*. Geotechnical Control Office, Civil Engineering Services Department, Hong Kong, 189 p.
- GCO (1990). *Review of Design Methods for Excavations (GCO Publication No. 1/90)*. Geotechnical Control Office, Civil Engineering Services Department, Hong Kong, 192 p.
- *GEO (1993). *Guide to Retaining Wall Design (Geoguide 1). (2nd Edition)*. Geotechnical Engineering Office, Civil Engineering Department, Hong Kong, 258 p.
- GEO (2000a). *Highway Slope Manual*. Geotechnical Engineering Office, Civil Engineering Department, Hong Kong, 114 p.
- GEO (2000b). *Technical Guidelines on Landscape Treatment and Bio-engineering for Man-made Slopes and Retaining Walls (GEO Publication No. 1/2000)*. Geotechnical Engineering Office, Civil Engineering Department, Hong Kong, 146 p.
- *GEO (2001). *Model Specification for Soil Testing (Geospec 3)*. Geotechnical Engineering Office, Civil Engineering Department, Hong Kong, 340 p.
- *GEO (2003). *Guide to Slope Maintenance (Geoguide 5). (3rd Edition)*. Geotechnical Engineering Office, Civil Engineering Department, Hong Kong, 132 p.
- *GEO (2004a). *Updating of GEO Report No. 56 : Application of Prescriptive Measures to Slopes and Retaining Walls (2nd Edition) (GEO Technical Guidance Note No. 9)*. Geotechnical Engineering Office, Civil Engineering and Development Department, Hong Kong, 4 p.
- GEO (2004b). *Acceptance of Methods for Quality Control (GEO Technical Guidance Note No. 18)*. Geotechnical Engineering Office, Civil Engineering and Development Department, Hong Kong, 2 p.

- GEO (2006). *Hydraulic Design of Stepped Channels on Slopes (GEO Technical Guidance Note No. 27)*. Geotechnical Engineering Office, Civil Engineering and Development Department, Hong Kong, 16 p.
- *GEO (2007a). *Engineering Geological Practice in Hong Kong (GEO Publication No. 1/2007)*. Geotechnical Engineering Office, Civil Engineering and Development Department, Hong Kong, 278 p.
- GEO (2007b). *Update of GEO Publication No. 1/2000 - Technical Guidelines on Landscape Treatment and Bio-engineering for Man-made Slopes and Retaining Walls (GEO Technical Guidance Note No. 20)*. Geotechnical Engineering Office, Civil Engineering and Development Department, Hong Kong, 8 p.
- HCL (Halcrow China Limited) (2007). *Study on the Potential Effect of Blockage of Subsurface Drainage by Soil Nailing Works (GEO Report No. 218)*. Geotechnical Engineering Office, Civil Engineering and Development Department, Hong Kong, 102 p.
- HKG (1991). *Tree Planting and Maintenance in Hong Kong*. Hong Kong Government, Hong Kong, 53 p.
- *HKIE (2003). *Soil Nails in Loose Fill Slopes (A Preliminary Study) - Final Report*. Geotechnical Division, The Hong Kong Institution of Engineers, Hong Kong, 38 p.
- Jewell, R.A. & Pedley, M.J. (1992). Analysis for soil reinforcement with bending stiffness. *Journal of Geotechnical Engineering*, American Society of Civil Engineers, Vol. 118, No. 10, October, pp. 1505-1528.
- Jewell, R.A. & Wroth, C.P. (1987). Direct shear tests on reinforced sand. *Gèotechnique*, Vol. 37, No. 1, pp. 53-68.
- Krahn, J. (2003). The 2001 R.M. Hardy Lecture: The limits of limit equilibrium analyses. *Canadian Geotechnical Journal*, Vol. 40, No. 3, pp. 643-660.
- Lee, C.F. & OAP (Ove Arup & Partners Hong Kong Limited) (2007). *Review of Use of Non-destructive Testing in Quality Control in Soil Nailing Works (GEO Report No. 219)*. Geotechnical Engineering Office, Civil Engineering and Development Department, Hong Kong, 109 p.
- *Lui, B.L.S. & Shiu, Y.K. (2005). *Prescriptive Soil Nail Design for Concrete and Masonry Retaining Walls (GEO Report No. 165)*. Geotechnical Engineering Office, Civil Engineering and Development Department, Hong Kong, 76 p.
- Ng, F.H., Lau, M.F., Shum, K.W. & Cheung, W.M. (2008). *Review of Selected Landslides involving Soil-nailed Slopes (GEO Report No. 222)*. Geotechnical Engineering Office, Civil Engineering and Development Department, Hong Kong, 98 p.

- Pun, W.K. & Shiu, Y.K. (2007). Design Practice and Technical Developments of Soil Nailing in Hong Kong. *Proceedings of the HKIE Geotechnical Division 27th Annual Seminar: Geotechnical Advancements in Hong Kong since 1970s*. The Hong Kong Institution of Engineers, Hong Kong, pp. 197-212.
- Shiu, Y.K. & Chang, G.W.K. (2005). *Soil Nail Head Review (GEO Report No. 175)*. Geotechnical Engineering Office, Civil Engineering and Development Department, Hong Kong, 106 p.
- Shiu, Y.K., Chang, G.W.K. & Cheung, W.M. (2007). *Review of Limit Equilibrium Methods for Soil Nail Design (GEO Report No. 208)*. Geotechnical Engineering Office, Civil Engineering and Development Department, Hong Kong, 107 p.
- Watkins, A.T. & Powell, G.E. (1992). Soil nailing to existing slopes as landslip preventive works. *Hong Kong Engineer*, March, Hong Kong, pp. 20-27.
- *Wong, H.N., Pang, L.S., Wong, A.C.W., Pun, W.K. & Yu, Y.F. (1999). *Application of Prescriptive Measures to Slopes and Retaining Walls (GEO Report No. 56)*. Geotechnical Engineering Office, Civil Engineering Department, Hong Kong, 73 p.
- Yue, Z.Q., Lee, C.F., Law, K.T. & Tham, L.G. (2004). Automatic monitoring of rotary-percussive drilling for ground characterization - illustrated by a case example in Hong Kong. *International Journal of Rock Mechanics and Mining Science*, Vol. 41, pp. 573-612.

GLOSSARY OF SYMBOLS

GLOSSARY OF SYMBOLS

A'	Effective cross-sectional area of a soil-nail reinforcement
B	Width of a retaining wall base
c'	Cohesion of soil under effective stress conditions
c_{ss}	Steady state undrained shear strength
D	Outer diameter of a cement grout sleeve
e	Eccentricity
F_a	Activating force
F_{SG}	Factor of safety against pullout failure at soil-grout interface
F_{GR}	Factor of safety against pullout failure at grout-reinforcement interface
F_r	Resisting force
F_S	Factor of safety against failure of a retaining wall
F_T	Factor of safety against tensile failure of soil-nail reinforcement
f_{cu}	Characteristic strength of cement grout
f_y	Characteristic yield strength of a soil-nail reinforcement
h	Depth of overburden directly above a soil-nail reinforcement
L	Bond length of soil-nail reinforcement in the passive zone
M_o	Overturning moment
M_r	Resisting moment
N_I	Normal reaction on a retaining wall base
P_a	Force acting on a retaining wall due to active earth pressure
P_{ah}	Horizontal component of force P_a
P_{av}	Vertical component of force P_a
P_c	Outer perimeter of a cement grout sleeve
P_r	Effective perimeter of a soil-nail reinforcement
pH	Value of acidity of an aqueous solution

p'_{peak}	Mean effective stress
Q_n	Effective normal load imposed on a foundation
Q_s	Effective shear load imposed on a foundation
Q_{ult}	Ultimate resistance against bearing capacity failure of a foundation
R_p	Resultant resistance force acting on a trial failure surface in soil due to passive earth pressure
r_u	Pore pressure parameter
S	Resisting force acting against sliding of a retaining wall
T	Design load of a soil nail
T_a	Initial load for a pullout test
T_c	Creep test load for a creep test
T_{DL1}, T_{DL2}	Intermediate loads for a pullout test
T_i	Force of the i^{th} row soil nail acting on a retaining wall
T_{ih}	Horizontal component of force T_i
T_{iv}	Vertical component of force T_i
T_{SG}	Allowable pullout resistance provided by the soil-grout bond length in the passive zone
T_p	90% yield load of reinforcement for a pullout test
T_{GR}	Allowable pullout resistance provided by the grout-reinforcement bond length in the passive zone
T_T	Allowable tensile strength of a soil-nail reinforcement
T_{ult}	Ultimate ground-grout bond load for a pullout test
U_1, U_2	Forces acting on a trial failure surface in soil due to water pressure
U_{1h}	Horizontal component of force U_1
U_{1v}	Vertical component of force U_1
u	Pore water pressure
W	Weight
w	Size of a square soil-nail head

$x_p, x_i, \text{ etc.}$	Horizontal distances between the toe of a retaining wall and points of action of forces acting on the wall
$y_p, y_i, \text{ etc.}$	Vertical distances between the toe of a retaining wall and points of action of forces acting on the wall
α	Tilt angle of a retaining wall back face to the vertical
α_s	Inclination of a soil nail
β	Coefficient of friction at the grout-reinforcement interface
β_s	Slope angle
δ	Angle of wall friction
ϕ'	Angle of shearing resistance of soil under effective stress condition
γ	Unit weight of soil
θ	Soil-nail orientation, which is the angle between a soil nail and the normal to the potential failure surface of soil
μ^*	Coefficient of apparent friction of soil
τ_{EXT}	Extra shearing resistance due to reinforcement
σ'_v	Vertical effective stress acting at a soil-nail reinforcement
σ_{yy}	Vertical stress on shear plane

GLOSSARY OF TERMS

GLOSSARY OF TERMS

Active zone. A region in front of the potential failure surface of a slope, where it has a tendency to detach from the slope.

Buildability. The extent to which the design and detailing of a soil-nailed system facilitates ease of construction subject to the overall requirements for the completion of works.

Cement grout sleeve. Cement grout, made of Portland cement and water, is placed between the soil-nail reinforcement and the ground.

Design life of soil nail. The period of time for which a soil nail is expected to perform its intended function.

Drill-and-grout soil nail. A soil nail of which the soil-nail reinforcement is installed in a pre-drilled hole, which is then cement-grouted under gravity or low pressure.

Driven soil nail. A soil nail of which the soil-nail reinforcement is directly driven into the ground by ballistic, percussive or vibratory method.

Inclination of a soil nail. The angle between the major axis of a soil nail and the horizontal.

Orientation of a soil nail. The angle between the major axis of a soil nail and the normal to the potential failure surface.

Passive zone. A region behind the potential failure surface of a slope, where it remains more or less intact.

Prescriptive measures. Pre-determined, experience-based and suitably conservative modules of works prescribed to a slope or retaining wall to improve its stability or reduce the risk of failure, without detailed ground investigations and design analyses. These generally involve conventional and conservative details in design, and attention to specification and control of materials, workmanship, protection and maintenance procedures.

Preventive maintenance works. Works of a preventive nature to reduce the rate of deterioration of a slope or retaining wall. These generally involve the use of prescriptive measures, and are more substantial than routine maintenance works.

Saprolite. Soil derived from insitu rock weathering in which evidence of the original rock texture, fabric and structure is retained.

Self-drilling soil nail. A soil nail of which the soil-nail reinforcement is drilled directly into the ground using a sacrificial drill bit with the reinforcement as a drill rod. The soil nail is cement-grouted using the hollow reinforcement as a grout pipe during installation.

Slope facing. A covering to the exposed face of the slope that serves to provide the slope with surface protection, and to minimise erosion and other adverse effects of surface water on the slope. It can be structural or non-structural. A structural slope facing can enhance the stability of a soil-nailed system by transfer of loads among the facing, the soil-nail heads and the soil nails.

Soil aggressivity. The corroding power of a soil, which is usually measured by a series of field and laboratory tests on the soil specimens.

Soil nail. A reinforcing element, usually installed at a sub-horizontal angle to the ground, that mobilises friction along its full length with the ground.

Soil nails carrying sustained load. Soil nails that carry an on-going load throughout their design life.

Soil nails carrying transient load. Soil nails that carry a momentary load, which only endures for a short period of time. An example of the transient load is the load arising from the rise of groundwater level following heavy rainfall.

Soil-nail head. A reinforced concrete pad associated with steel bearing plate and nuts that provides a reaction for individual soil nails to mobilise tensile forces and to promote local stability between soil nails.

Soil-nail reinforcement. Main reinforcing element of a soil nail, which provides the tensile resistance.

Soil-nailed excavation. A soil-nailed system is considered to be a soil-nailed excavation if the reinforcing bars in an excavation, which carry either transient or sustained loads, are designed to perform as soil nails.

Soil-nailed retaining wall. A soil-nailed system in which the facing is sub-vertical, and is designed to perform as a structural member which provides retention action to the ground by virtue of its self-weight, bending strength or stiffness. For example, if soil nails are installed into a gravity, reinforced concrete or cantilevered retaining wall, the system is considered as a soil-nailed retaining wall.

Soil-nailed slope. A slope, which is reinforced by installing reinforcement that improves the stability of the system through mobilisation of tensile forces in the reinforcement.

Soil-nailed system. A slope, a retaining wall or an excavation, which is reinforced by installing reinforcement that improves the stability of the system through mobilisation of tensile forces in the reinforcement.

Test soil nail. A soil nail installed using the same procedures as the working soil nails for the purpose of testing.

Upgrading works. Works carried out to upgrade a substandard slope or a retaining wall to the requirements stipulated in the current geotechnical standards.

Urgent repair works. Works carried out to render an area affected by a landslide temporarily safe. Since permanent remedial works may take some time to initiate and complete, urgent repair works are aimed at ensuring that the area will not deteriorate in the interim to an extent that would pose an immediate danger.

Working soil nails. Soil nails which are designed analytically or prescriptively so as to improve the stability of slopes, retaining walls, excavations, disturbed terrain or natural hillsides.

GEO PUBLICATIONS AND ORDERING INFORMATION

土力工程處刊物及訂購資料

A selected list of major GEO publications is given in the next page. An up-to-date full list of GEO publications can be found at the CEDD Website <http://www.cedd.gov.hk> on the Internet under "Publications". Abstracts for the documents can also be found at the same website. Technical Guidance Notes are published on the CEDD Website from time to time to provide updates to GEO publications prior to their next revision.

Copies of GEO publications (except maps and other publications which are free of charge) can be purchased either by:

writing to

Publications Sales Section,
Information Services Department,
Room 402, 4th Floor, Murray Building,
Garden Road, Central, Hong Kong.
Fax: (852) 2598 7482

or

- Calling the Publications Sales Section of Information Services Department (ISD) at (852) 2537 1910
- Visiting the online Government Bookstore at <http://www.bookstore.gov.hk>
- Downloading the order form from the ISD website at <http://www.isd.gov.hk> and submit the order online or by fax to (852) 2523 7195
- Placing order with ISD by e-mail at puborder@isd.gov.hk

1:100 000, 1:20 000 and 1:5 000 maps can be purchased from:

Map Publications Centre/HK,
Survey & Mapping Office, Lands Department,
23th Floor, North Point Government Offices,
333 Java Road, North Point, Hong Kong.
Tel: 2231 3187
Fax: (852) 2116 0774

Requests for copies of Geological Survey Sheet Reports, publications and maps which are free of charge should be sent to:

For Geological Survey Sheet Reports and maps which are free of charge:

Chief Geotechnical Engineer/Planning,
(Attn: Hong Kong Geological Survey Section)
Geotechnical Engineering Office,
Civil Engineering and Development Department,
Civil Engineering and Development Building,
101 Princess Margaret Road,
Homantin, Kowloon, Hong Kong.
Tel: (852) 2762 5380
Fax: (852) 2714 0247
E-mail: jsewell@cedd.gov.hk

For other publications which are free of charge:

Chief Geotechnical Engineer/Standards and Testing,
Geotechnical Engineering Office,
Civil Engineering and Development Department,
Civil Engineering and Development Building,
101 Princess Margaret Road,
Homantin, Kowloon, Hong Kong.
Tel: (852) 2762 5346
Fax: (852) 2714 0275
E-mail: wmcheung@cedd.gov.hk

部份土力工程處的主要刊物目錄刊載於下頁。而詳盡及最新的土力工程處刊物目錄，則登載於土木工程拓展署的互聯網網頁 <http://www.cedd.gov.hk> 的“刊物”版面之內。刊物的摘要及更新刊物內容的工程技術指引，亦可在這個網址找到。

讀者可採用以下方法購買土力工程處刊物(地質圖及免費刊物除外):

書面訂購

香港中環花園道
美利大廈4樓402室
政府新聞處
刊物銷售組
傳真: (852) 2598 7482

或

- 致電政府新聞處刊物銷售小組訂購 (電話: (852) 2537 1910)
- 進入網上「政府書店」選購，網址為 <http://www.bookstore.gov.hk>
- 透過政府新聞處的網站 (<http://www.isd.gov.hk>) 於網上遞交訂購表格，或將表格傳真至刊物銷售小組 (傳真: (852) 2523 7195)
- 以電郵方式訂購 (電郵地址: puborder@isd.gov.hk)

讀者可於下列地點購買1:100 000, 1:20 000及1:5 000地質圖:

香港北角渣華道333號
北角政府合署23樓
地政總署測繪處
電話: 2231 3187
傳真: (852) 2116 0774

如欲索取地質調查報告、其他免費刊物及地質圖，請致函:

地質調查報告及地質圖:

香港九龍何文田公主道101號
土木工程拓展署大樓
土木工程拓展署
土力工程處
規劃部總土力工程師
(請交:香港地質調查組)
電話: (852) 2762 5380
傳真: (852) 2714 0247
電子郵件: jsewell@cedd.gov.hk

其他免費刊物:

香港九龍何文田公主道101號
土木工程拓展署大樓
土木工程拓展署
土力工程處
標準及測試部總土力工程師
電話: (852) 2762 5346
傳真: (852) 2714 0275
電子郵件: wmcheung@cedd.gov.hk

MAJOR GEOTECHNICAL ENGINEERING OFFICE PUBLICATIONS

土力工程處之主要刊物

GEOTECHNICAL MANUALS

Geotechnical Manual for Slopes, 2nd Edition (1984), 300 p. (English Version), (Reprinted, 2000).

斜坡岩土工程手冊(1998), 308頁(1984年英文版的中文譯本)。

Highway Slope Manual (2000), 114 p.

GEOGUIDES

Geoguide 1 Guide to Retaining Wall Design, 2nd Edition (1993), 258 p. (Reprinted, 2007).

Geoguide 2 Guide to Site Investigation (1987), 359 p. (Reprinted, 2000).

Geoguide 3 Guide to Rock and Soil Descriptions (1988), 186 p. (Reprinted, 2000).

Geoguide 4 Guide to Cavern Engineering (1992), 148 p. (Reprinted, 1998).

Geoguide 5 Guide to Slope Maintenance, 3rd Edition (2003), 132 p. (English Version).

岩土指南第五冊 斜坡維修指南, 第三版(2003), 120頁(中文版)。

Geoguide 6 Guide to Reinforced Fill Structure and Slope Design (2002), 236 p.

Geoguide 7 Guide to Soil Nail Design and Construction (2008), 97 p.

GEOSPECS

Geospec 1 Model Specification for Prestressed Ground Anchors, 2nd Edition (1989), 164 p. (Reprinted, 1997).

Geospec 3 Model Specification for Soil Testing (2001), 340 p.

GEO PUBLICATIONS

GCO Publication No. 1/90 Review of Design Methods for Excavations (1990), 187 p. (Reprinted, 2002).

GEO Publication No. 1/93 Review of Granular and Geotextile Filters (1993), 141 p.

GEO Publication No. 1/2000 Technical Guidelines on Landscape Treatment and Bio-engineering for Man-made Slopes and Retaining Walls (2000), 146 p.

GEO Publication No. 1/2006 Foundation Design and Construction (2006), 376 p.

GEO Publication No. 1/2007 Engineering Geological Practice in Hong Kong (2007), 278 p.

GEOLOGICAL PUBLICATIONS

The Quaternary Geology of Hong Kong, by J.A. Fyfe, R. Shaw, S.D.G. Campbell, K.W. Lai & P.A. Kirk (2000), 210 p. plus 6 maps.

The Pre-Quaternary Geology of Hong Kong, by R.J. Sewell, S.D.G. Campbell, C.J.N. Fletcher, K.W. Lai & P.A. Kirk (2000), 181 p. plus 4 maps.

TECHNICAL GUIDANCE NOTES

TGN 1 Technical Guidance Documents