

DOME-SHAPE METAL CAP WELDED ON TOP OF HOLLOW SECTION

DN25 HEAVY SERIES MILD STEEL TUBE

DN40 MEDIUM SERIES MILD STEEL POST

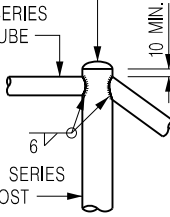

DETAIL 'A'

SCALE 1 : 10

OVERALL WIDTH TO BE SPECIFIED (600 MIN.)

5.5 DIA. x 32 LONG S.S. SELF-DRILLING SCREWS (ONLY IF WIRE MESH IS PROVIDED)

DN40 MEDIUM SERIES MILD STEEL POST (SEE NOTE 2)

6 x 25 S.S. COVER STRIP (ONLY IF WIRE MESH IS PROVIDED)

WIRE MESH (OPTIONAL)

SEE DETAILS OF STEEL ANGLE BASE

FINAL SLOPE PROFILE

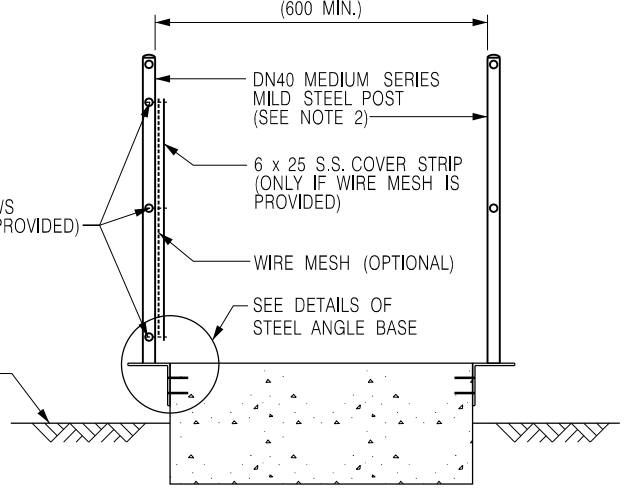

SECTION A - A

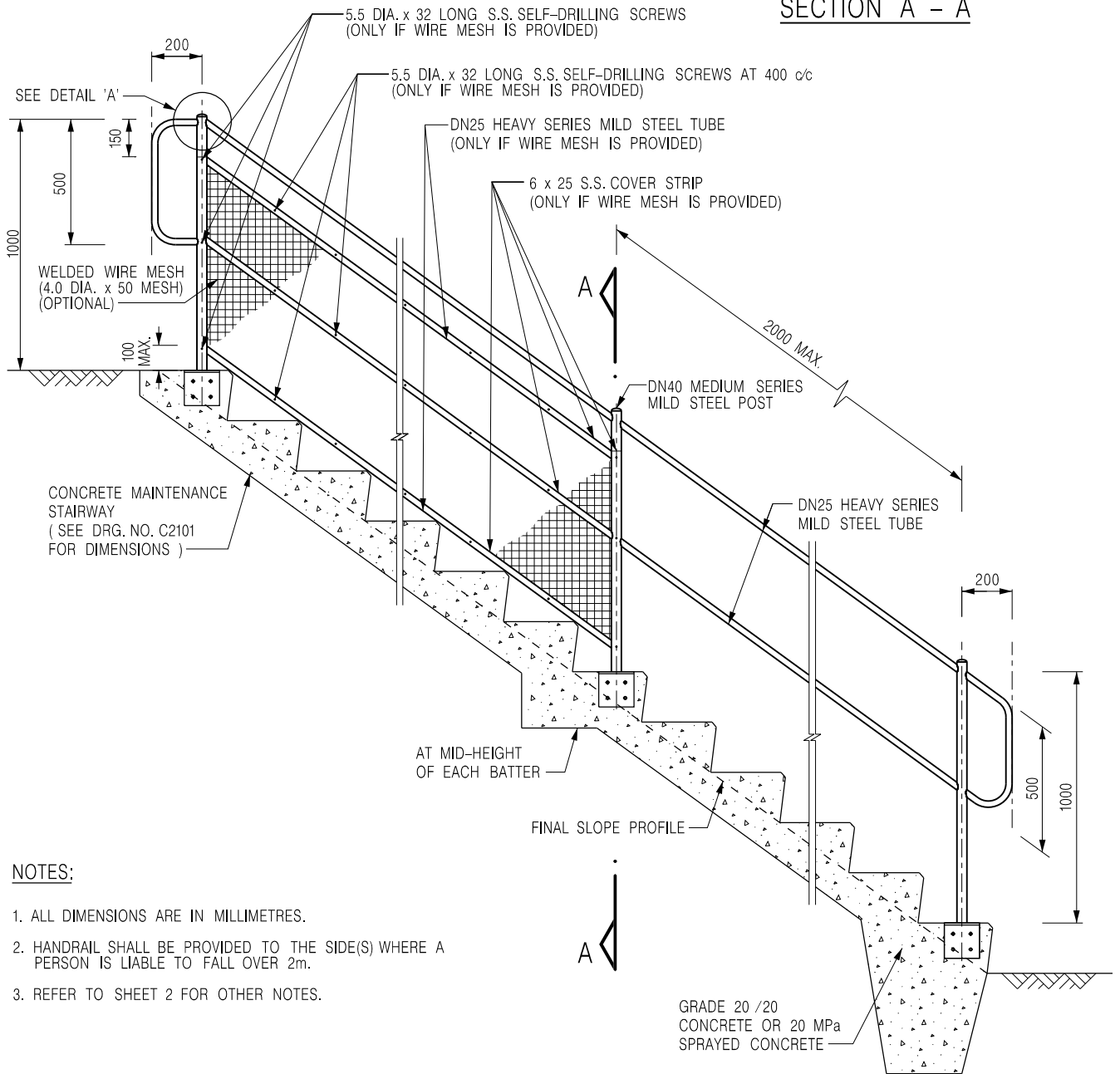

NOTES:

1. ALL DIMENSIONS ARE IN MILLIMETRES.
2. HANDRAIL SHALL BE PROVIDED TO THE SIDE(S) WHERE A PERSON IS LIABLE TO FALL OVER 2m.
3. REFER TO SHEET 2 FOR OTHER NOTES.

HANDRAILING TO MAINTENANCE STAIRWAY ON SLOPE (SHEET 1 OF 2)

FORMER DRG. NO. C2103K	Original Signed	08.2024
 CIVIL ENGINEERING AND DEVELOPMENT DEPARTMENT		
SCALE 1 : 25	DRAWING NO. C2103 /1	
DATE JAN 1991		